

## STRAPPO



Modello e design registrati, brevetto depositato  
Registered model and design, patent pending

**Articolo:** STRAPPO / STRAPPOL  
**Materiale:** Corian  
**Trooppieno:** NO  
**Portata:** l/s 0,52  
**Peso lordo:** kg 75 ca.  
**Peso netto:** kg 37 ca.  
**Dimensione imballo:** cm 90 x 93 x 69

**Descrizione:** Lavabo da incasso a parete in Corian, con o senza illuminazione a led, completo di piletta ispezionabile, sifone e tubo flessibile.

**Article:** STRAPPO / STRAPPOL  
**Material:** Corian  
**Overflow:** NO  
**Flow rate:** l/s 0,52  
**Gross weight:** kg 75 ca.  
**Net weight:** kg 37 ca.  
**Packing dimensions:** cm 90 x 93 x 69

**Description:** Encased Corian sink with or without led lighting, complete with inspectable drain, trap and flexible hose.

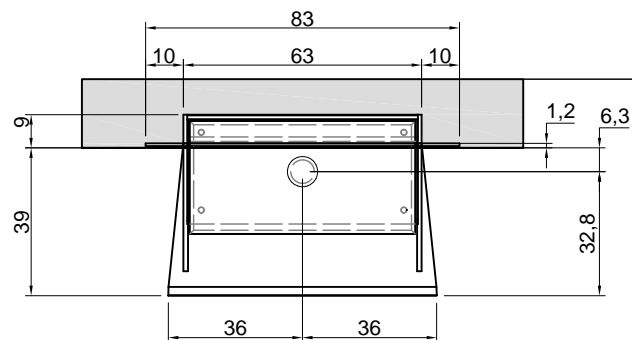
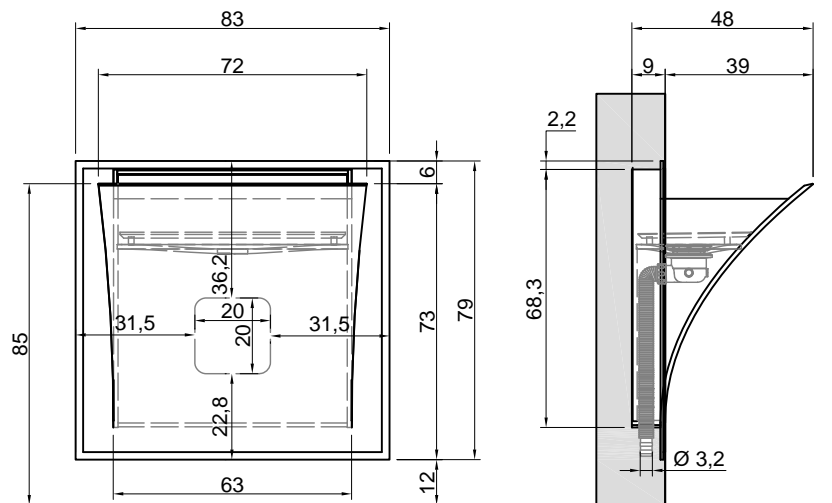

STRAPPO - Schema elettrico - electrical diagram

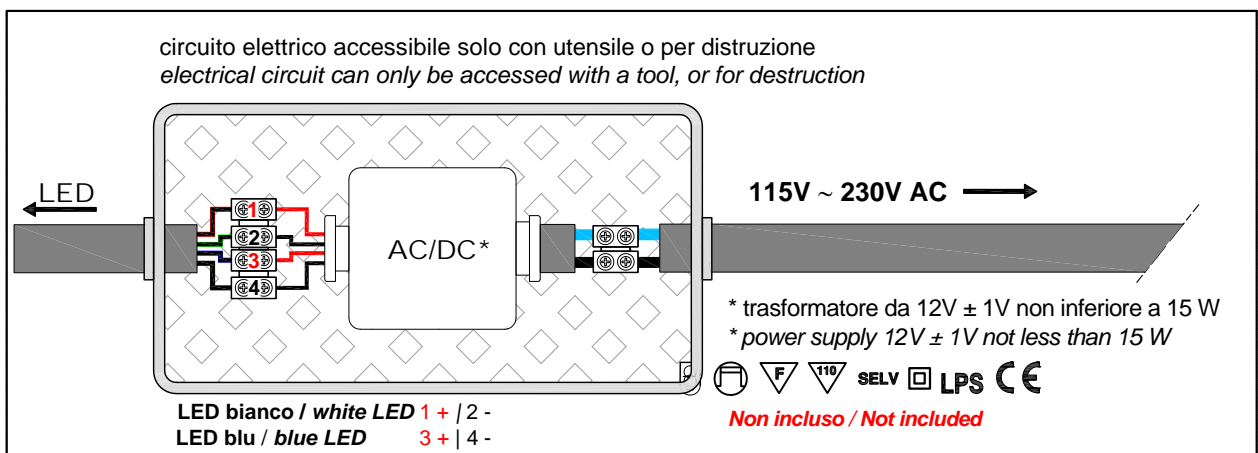
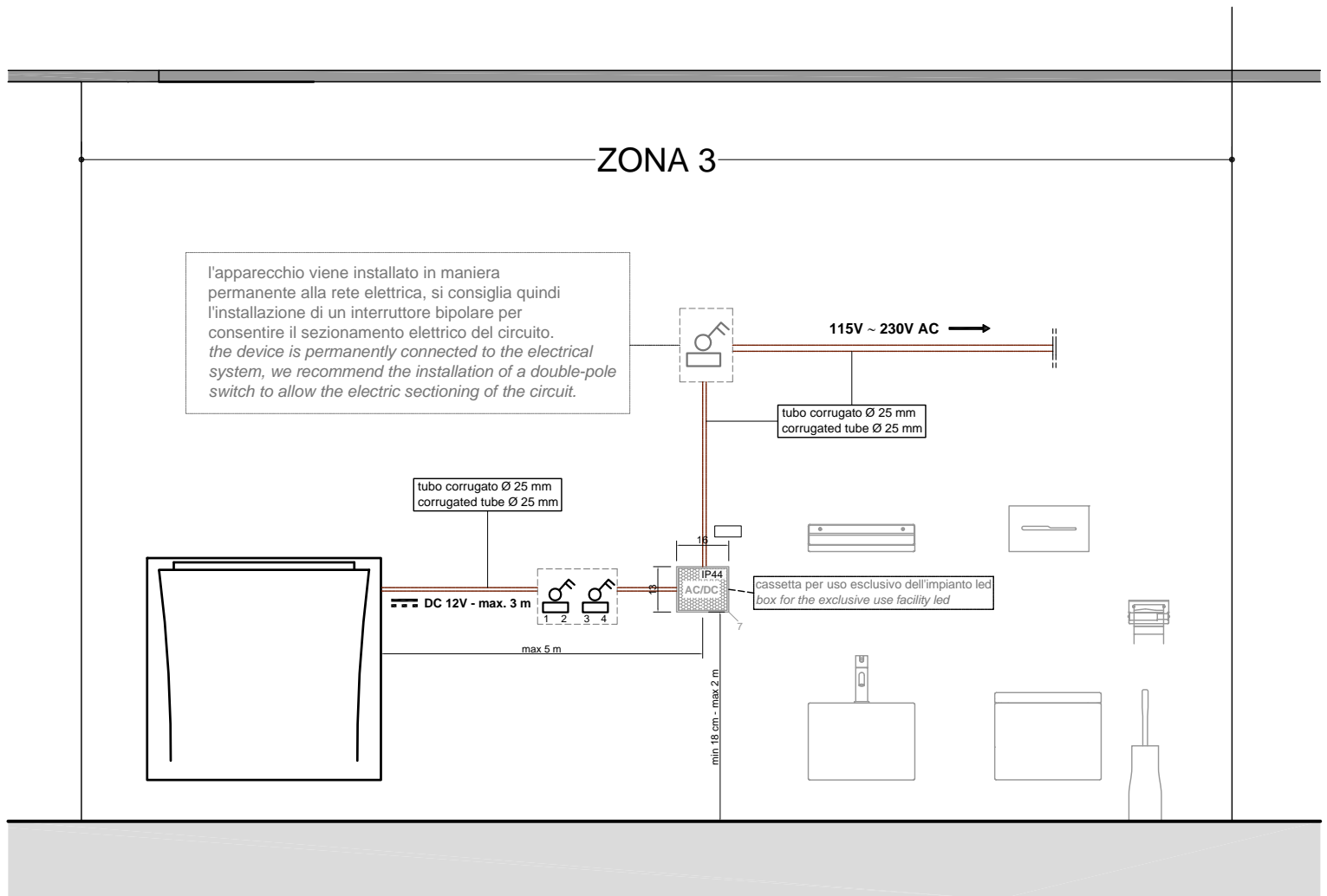

STRAPPO - Schema d' installazione / Installation layout

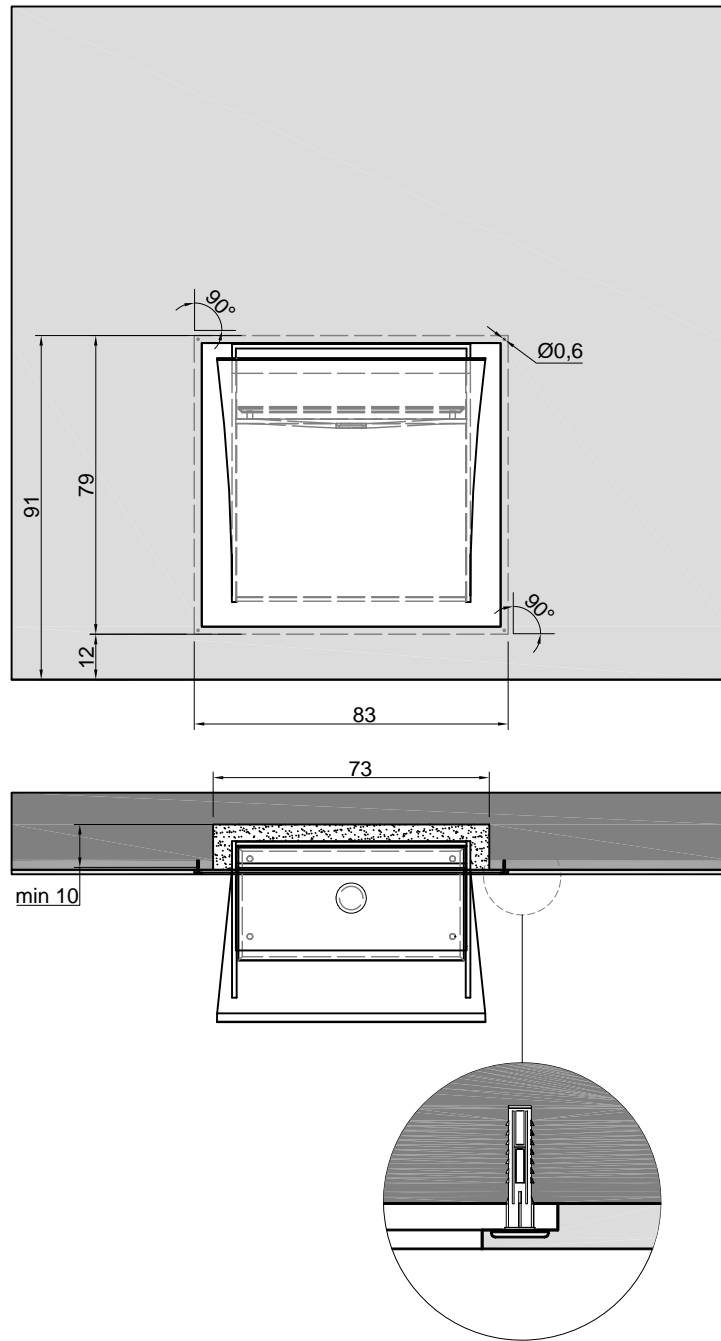

## STRAPPO - Pulizia - ispezione sifone / Cleaning - inspection siphon

