

Rubinetti
Mixers

BOSSINI



Index

Oki Line

Cube Line

Liberty Line

Stainless Steel Collections

HIGH FLOW Thermostatic mixers 1-6 outlets

Alta portata HP (High Pressure)

Alta portata LP (Low Pressure)

Informazioni Tecniche / Technical information

Shower installation solutions

Universal Mixers

Parti di Ricambio / Spare Parts

Since 1960 - Made in Italy

History

Unità produttive



Design, qualità e una continua ricerca tecnologica volta all'innovazione stanno alla base del successo che dal 1960 accompagna la costante crescita di Bossini Spa in Italia e nel mondo.

Fondata da Leonardo Bossini, la società si avvale oggi dell'operato di 168 dipendenti all'interno di due unità produttive ed esporta in oltre 60 Paesi nel mondo

Leader riconosciuta nel mercato docce e accessori, Bossini si rivolge con i suoi prodotti ad una clientela posizionata in un target medio-alto garantendo alti standard di sicurezza, una particolare attenzione all'impatto ambientale ed il massimo della funzionalità.

Certificata UNI EN ISO 9001/2015, IATF 16949: 2016 e UNI EN ISO 14001-2015, Bossini è sinonimo di qualità di prodotto e, grazie ad una sempre rinnovata strategia commerciale, è in grado di rispondere a qualsiasi richiesta avanzata dal mercato, orientandosi per particolari progetti della propria clientela sul tailor made only made in Italy.



Production plants

Design, quality and continuous technological research centred on innovation are the foundation of the success that, since 1960, has accompanied Bossini Spa in its persistent growth, both in Italy and around the world.

Founded by Leonardo Bossini, today the company is supported by a team of 168 employees across two production units and exports to over 60 countries around the world

A recognised leader in the shower and accessories market, Bossini's products are aimed at customers in the medium-high target group, guaranteeing high standards of security, special attention to the environmental impact and maximum functionality.

UNI EN ISO 9001:2015, IATF 16949: 2016 and UNI EN ISO 14001:2015 certified, Bossini is synonymous with product quality and, thanks to a constantly renewed business strategy, it is capable of responding to any demands presented by the market, with Bossini basing specific projects undertaken for its clients on the tailor-made, only made in Italy concept.

Projects Reference



Burj al-Arab
Abu Dhabi
United Arab Emirates



Hotel La Lama
Roma
Italy



Hotel Mondial
Berlin
Germany



MGM
Las Vegas
USA

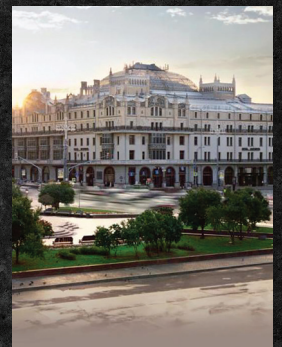

Hotel Metropol
Moscow
Russia



Euler Hotel
Basel
Switzerland



Hotel Le Royal Monceau
Paris
France



Hotel Ritz
Barcelona
Spain

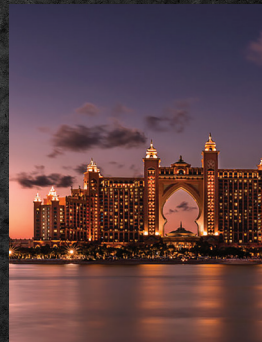

Atlantis The Palm
Dubai
United Arab Emirates



Bluewaters Island
Dubai
United Arab Emirates



Oki Line

Per chi ama la perfezione del cerchio

Oki for the perfection of the circle

Die Vollkommenheit des Kreises

La perfection du cercle

La perfección del círculo

Для тех, кто любит совершенство круга

Z005301 LAVABO OKI

Packaging Box: 8 pz/pcs
25x40x60

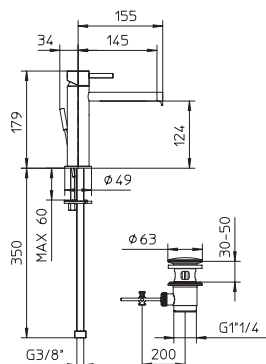

Miscelatore monocomando lavabo con scarico 1"1/4.
Single lever basin mixer with 1"1/4 pop-up waste.
Einhebel Waschtischmischer mit Ablaufgarnitur 1"1/4.
Mitigeur mecanique lavabo avec vidage 1"1/4.
Monomando lavabo con desagüe 1"1/4.
Смеситель для раковины с заглушкой 1"1/4.

Codice/Code	Finitura/Finish
Z005301	030 cromo/chrome
	021 oro/gold
	073 nero opaco/mat black
	094 nichel sp./satin nickel

Z005303 LAVABO OKI

Packaging Box: 8 pz/pcs
25x40x60

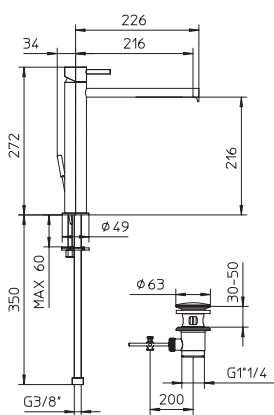

Miscelatore monocomando alto lavabo con scarico 1"1/4.
High single lever basin mixer with 1"1/4 pop-up waste.
Hoch Einhebel Waschtischmischer mit Ablaufgarnitur 1"1/4.
Mitigeur mecanique lavabo haut avec vidage 1"1/4.
Monomando lavabo alto con desagüe 1"1/4.
Смеситель для раковины высокий с заглушкой 1"1/4.

Codice/Code	Finitura/Finish
Z005303	030 cromo/chrome
	021 oro/gold
	073 nero opaco/mat black
	094 nichel sp./satin nickel

Z005401 BIDET OKI

Packaging Box: 8 pz/pcs
25x40x60

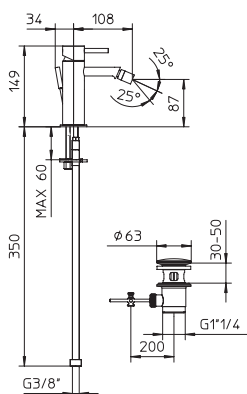

Miscelatore monocomando bidet con scarico 1"1/4.
Single lever bidet mixer with 1"1/4 pop-up waste.
Einhebel Bidetmischer mit Ablaufgarnitur 1"1/4.
Mitigeur mecanique de bidet avec vidage 1"1/4.
Monomando bidé con desagüe 1"1/4.
Смеситель для биде с заглушкой 1"1/4.

Codice/Code	Finitura/Finish
Z005401	030 cromo/chrome
	021 oro/gold
	073 nero opaco/mat black
	094 nichel sp./satin nickel

Z000301

Packaging Box: 8 pz/pcs
13x7,5x7,5

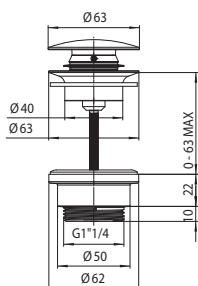

Piletta di scarico Clic Clac 1" 1/4
1" 1/4 Click Clack waste
Ablaufventil Click-Clack 1" 1/4
Vidage Clic Clac 1" 1/4
Válvula desagüe Click Clack 1" 1/4
Сливом Clic-Clac 1" 1/4

Codice/Code	Finitura/Finish
Z000301	030 cromo/chrome
	021 oro/gold
	073 nero opaco/mat black
	094 nichel sp./satin nickel

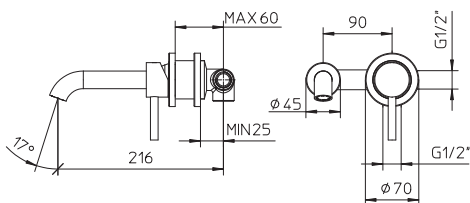
Z005302 LAVABO OKI

Packaging Box: 8 pz/pcs
25x40x60

Miscelatore monocomando da incasso con bocca fissa 22 cm, senza scarico.

Concealed wash basin mixer, 22 cm fixed spout, without waste.

Einhebel Waschtischmischer Unterputz, fester Auslauf 22 cm, ohne Ablaufgarnitur.

Mélangeur mécanique lavabo mural, avec bec fixe 22 cm, sans vidage.

Monomando lavabo mural empotrat, caño fijo 22 cm, sin desagüe.

Смеситель механический встраиваемый с изливом 22 см, без заглушки.

Codice/Code	Finitura/Finish
Z005302	030 cromo/chrome
	021 oro/gold
	073 nero opaco/mat black
	094 nichel sp./satin nickel

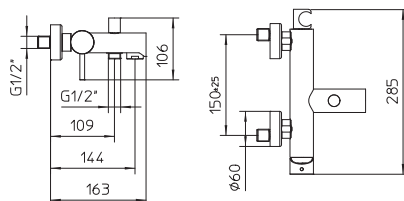
Z005101 VASCA-DOCCIA OKI

Packaging Box: 8 pz/pcs
25x40x60

Miscelatore monocomando esterno con deviatore automatico, supporto doccia fisso integrato e attacco flessibile 1/2\".

Exposed single lever bath/shower mixer with automatic diverter, fixed shower bracket and 1/2\" hose connection.

Einhebel Wannenmischer Aufputz, automatischer Umsteller, Brausehalter und Brauseschlauchanschluss 1/2\".

Mitigeur mécanique bain douche avec inverseur, automatique support de douche fixe et sortie pour flexible 1/2\".

Monomando baño-ducha con desviador, automático soporte de ducha fijo y salida por flexible de 1/2\".

Смеситель наружный с автоматическим девиатором, интегрированный держатель для душевой лейки и гибкое соединение 1/2\".

Codice/Code	Finitura/Finish
Z005101	030 cromo/chrome
	021 oro/gold
	073 nero opaco/mat black
	094 nichel sp./satin nickel

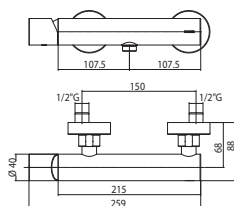
Z005130 DOCCIA MONOCOMANDO ESTERNO OKI

Packaging Box: 12 pz/pcs
35x50x35

Miscelatore monocomando esterno doccia con uscita da 1/2\"

Exposed single lever shower mixer with 1/2\" outlet

Aufputz Einhebel Brausebatterie mit 1/2\" Schlauchanschluss

Mitigeur mécanique de douche avec connexion flexible 1/2\"

Monomando ducha con conexión flexible de 1/2\"

Наружная душевая группа с выходом на 1/2\"

Codice/Code	Finitura/Finish
Z005130	030 cromo/chrome
	021 oro/gold
	073 nero opaco/mat black
	094 nichel sp./satin nickel

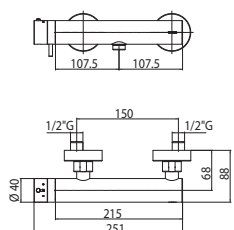
Z005131 DOCCIA TERMOSTATICO ESTERNO OKI

Packaging Box: 12 pz/pcs
35x50x35

Miscelatore termostatico esterno doccia con uscita da 1/2\"

Exposed thermostatic shower mixer with 1/2\" outlet

Aufputz Thermostat Brausebatterie mit 1/2\" Schlauchanschluss

Mitigeur de douche thermostatique avec connexion flexible 1/2\"

Termostático ducha con conexión flexible 1/2\"

Наружная душевая группа с выходом на 1/2\"

Codice/Code	Finitura/Finish
Z005131	030 cromo/chrome
	021 oro/gold
	073 nero opaco/mat black
	094 nichel sp./satin nickel

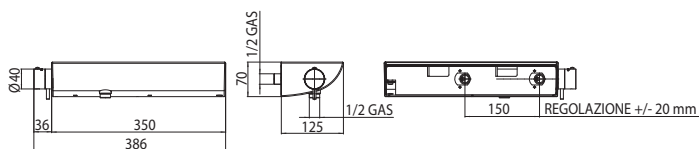
V40004 MISCELATORE TERMOSTATICO - THERMOSTATIC MIXER

Miscelatore termostatico esterno con mensola portaoggetti e ripiano in vetro, con uscita da 1/2"

Exposed thermostatic shower mixer complete with shelf and glass plate, with 1/2" outlet

Aufputz Thermostat Brausebatterie mit Ablage und Platte aus Glas, mit 1/2" Schlauchanschlüssen

Mitigeur thermostatique externe pour douche avec étagère et plaque en verre, connection flexible 1/2"

Mezclador ducha termostático externo con repisa y estante en vidrio, con conexión flexible 1/2"

Смеситель термостатический наружный в комплекте с подставкой и полкой из стекла, подключение 1/2"

Codice/Code

Finitura/Finish

V40004

030 cromo/chrome

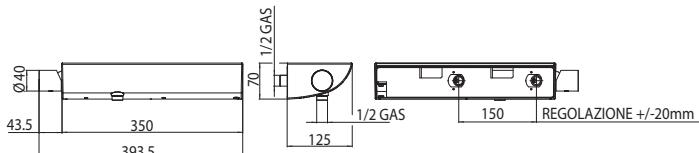
V40003 MISCELATORE MONOCOMANDO - SINGLE LEVER MIXER

Miscelatore monocomando esterno con mensola portaoggetti e ripiano in vetro, con uscita da 1/2"

Exposed single lever shower mixer complete with shelf and glass plate, with 1/2" outlet

Aufputz Einhebelbrausebatterie mit Ablage und Platte aus Glas, mit 1/2" Schlauchanschlüssen

Mitigeur mécanique externe pour douche avec étagère et plaque en verre, connection flexible 1/2"

Mezclador ducha monomando externo con repisa y estante en vidrio, con conexión flexible 1/2"

Смеситель механический наружный в комплекте с подставкой и полкой из стекла, подключение 1/2"

Codice/Code

Finitura/Finish

V40003

030 cromo/chrome

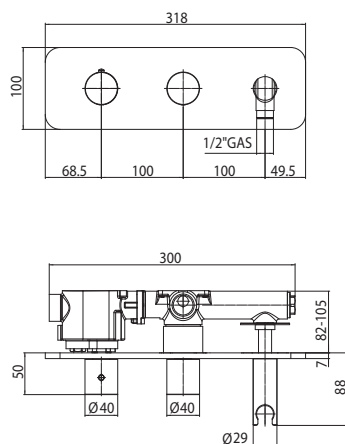
Z005350 MISCELATORE TERMOSTATICO 2 VIE - 2 WAYS THERMOSTATIC MIXER

Miscelatore termostatico alta portata con deviatore 2 vie, supporto doccia e presa acqua, attacchi da 3/4"

High flow thermostatic mixer complete with 2-ways diverter and water supply with shower holder, 3/4" connections

Hochdurchfluss Thermostat-Mischbatterie mit 2-Wege Umsteller und Brausehalter mit Wandanschlussbogen, 3/4" Anschlüsse

Mitigeur thermostatique haut débit avec inverseur 2 voies et sortie murale avec support douchette, raccords 3/4"

Mezclador termostático de alta capacidad con desviador de 2 vías, soporte ducha con toma de agua, conexiones de 3/4"

Смеситель термостатический высокой пропускной способности с девиатором на 2 выхода и держателем с водорозеткой, подключение на 3/4"

Codice/Code

Finitura/Finish

Z005350

030 cromo/chrome

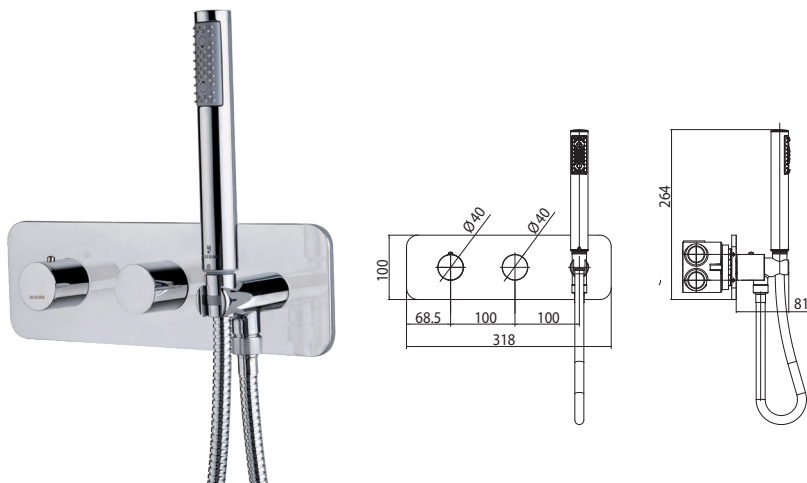
Z005351 KIT MISCELATORE TERMOSTATICO 2 VIE - KIT 2 WAYS THERMOSTATIC MIXER

Kit miscelatore termostatico alta portata con deviatore due vie, supporto doccia e presa acqua, attacchi da 3/4", doccia ZEN e flessibile doppia agg. 150 cm

Shower set consisting of high flow thermostatic mixer complete with 2-ways diverter and water supply with shower holder, 3/4" connections, ZEN hand shower and double interlock hose 150 cm

Duschset bestehend aus Hochdurchfluss Thermostat-Mischbatterie mit 2-Wege Umsteller und Brausehalter mit Wandanschlussbogen, 3/4" Anschlüsse, Handbrause ZEN mit Schlauch

Ensemble douche composé par mitigeur thermostatique haut débit, inverseur 2 voies, sortie murale avec support douchette, raccords 3/4", douchette ZEN et flexible double agrafage 150 cm

Conjunto ducha con mezclador termostático de alta capacidad, desviador de 2 vías, soporte ducha con toma de agua, conexiones de 3/4", mango ducha ZEN y flexible doble grafado 150 cm

Комплект: смеситель терmostатический высокой пропускной способности с девиатором на 2 выхода и держателем с водорозеткой, подключение на 3/4", ручной душ ZEN и шланг 150 cm

Codice/Code	Finitura/Finish
Z005351	030 cromo/chrome

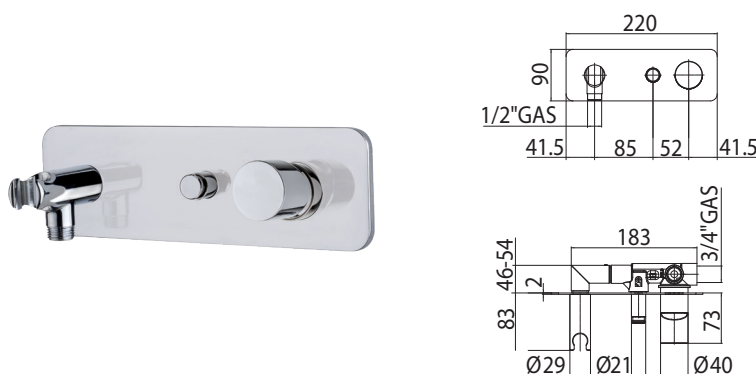
Z005360 MISCELATORE MONOCOMANDO 2 VIE - 2 WAYS SINGLE LEVER MIXER

Miscelatore monocomando con deviatore 2 vie, supporto doccia e presa acqua, attacchi da 1/2"

Single lever mixer complete with 2-ways diverter and water supply with shower holder, 1/2" connections

Unterputz-Einbaukörper für Einhebelbatterie mit 2-Wege Umsteller und Brausehalter mit Wandanschlussbogen, 1/2" Anschlüsse

Mitigeur mécanique avec inverseur 2 voies et sortie murale avec support douchette, raccords 1/2"

Mezclador monomando con desviador de 2 vías, soporte ducha con toma de agua, conexiones de 1/2"

Смеситель механический с девиатором на 2 выхода и держатель с водорозеткой, соединение на 1/2"

Codice/Code	Finitura/Finish
Z005360	030 cromo/chrome

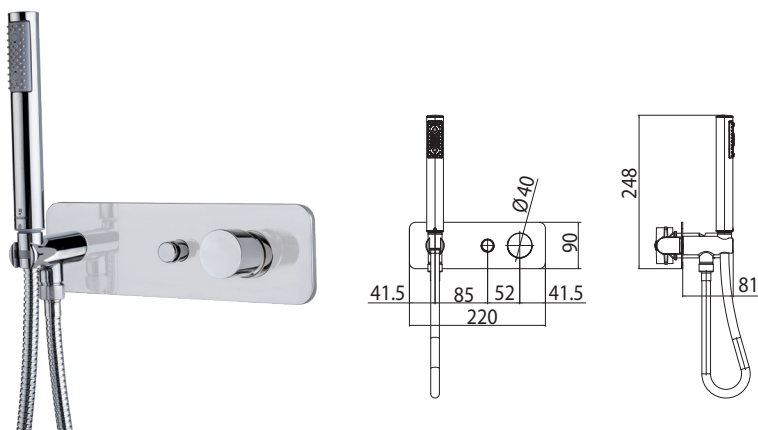
Z005361 KIT MISCELATORE MONOCOMANDO 2 VIE - KIT 2 WAYS SINGLE LEVER MIXER

Kit miscelatore monocomando con deviatore due vie, supporto doccia e presa acqua, attacchi da 1/2", doccia ZEN e flessibile doppia agg. 150 cm

Shower set consisting of single lever mixer with 2-ways diverter and water supply with shower holder, 1/2" connections, ZEN hand shower and double interlock hose 150 cm

Duschset bestehend aus Unterputz-Einbaukörper für Einhebelbatterie mit 2-Wege Umsteller und Brausehalter mit Wandanschlussbogen, 1/2" Anschlüsse, Handbrause ZEN mit Schlauch

Ensemble douche composé par mitigeur mécanique avec inverseur 2 voies et sortie murale avec support douchette, raccords 1/2", douchette ZEN et flexible double agrafage 150 cm

Conjunto ducha con mezclador monomando con desviador de 2 vías, soporte ducha con toma de agua, conexiones de 1/2", mango ducha ZEN y flexible doble grafado 150 cm

Комплект; смеситель механический с девиатором на 2 выхода и держатель с водорозеткой, соединение на 1/2", ручной душ ZEN и шланг

Codice/Code	Finitura/Finish
Z005361	030 cromo/chrome



Z00007 INCASSO MONOCOMANDO 1 VIA - 1 WAY SINGLE LEVER CONCEALED PART

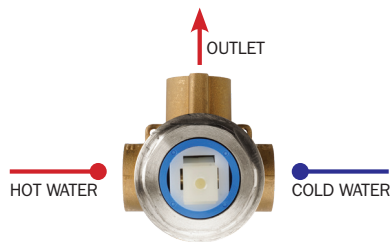
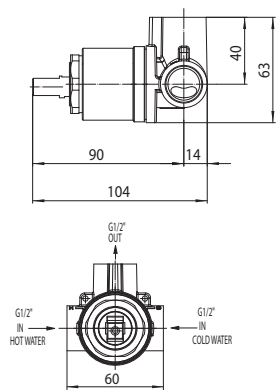

Parti incasso miscelatore monocomando 1 VIA, attacco da 1/2"
 Concealed parts for single lever mixer 1 WAY, 1/2" connection
 Unterputz-Einbaukörper für Einhebelbatterie, 1/2" Anschluss
 Parties à encastrer pour mitigeur mécanique 1 VOIE, connexion 1/2"
 Partes de empotrado mezclador monomando de 1 VÍA, conexión 1/2"
 Смеситель механический встраиваемый с девиатором 1 направления 1/2"

Packaging Box: 1 pz/pcs
 35x40x25

Codice/Code Uscite/Outlets

Z00007 1

Z00008 PARTI ESTERNE OKI - EXPOSED PARTS

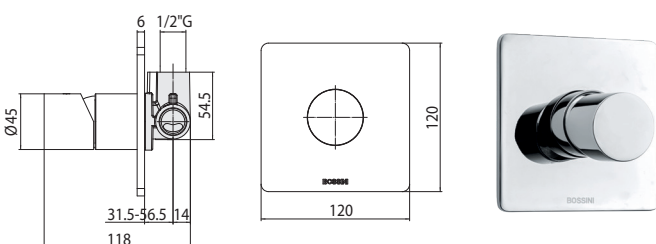

Parti esterne
 Exposed parts
 Aufputzteile
 Parties externes
 Partes externas
 Детали наружные/Детали наружные

Codice/Code Finitura/Finish

Z00008 030 cromo/chrome

021 oro/gold

073 nero opaco/mat black

094 nichel sp./satin nickel

Packaging Box: 1 pz/pcs
 35x40x25

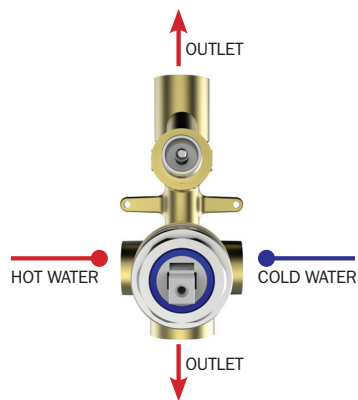
Z00005 INCASSO MONOCOMANDO 2 VIE - 2 WAY SINGLE LEVER CONCEALED PART

Parti incasso miscelatore monocomando con deviatore 2 VIE, attacchi da 1/2"

Concealed parts for single lever mixer with 2-WAYS diverter, 1/2" connections

Unterputz-Einbaukörper für Einhebelbatterie mit 2-WEGE Umsteller, 1/2" Anschlüsse

Parties à encastrer pour mitigeur mécanique avec inverseur 2 VOIES, connexions 1/2"

Partes de empotrado para mezclador monomando con desviador de 2 VIAS, conexiones 1/2"

Смеситель механический встраиваемый с девиатором 2 направления 1/2"

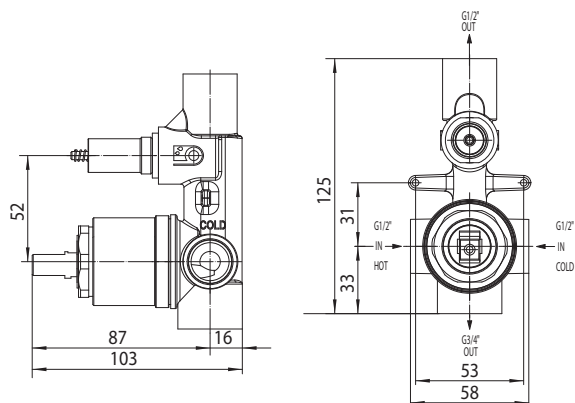

Packaging Box: 1 pz/pcs
35x40x25

Codice/Code

Uscite/Outlets

Z00005

2

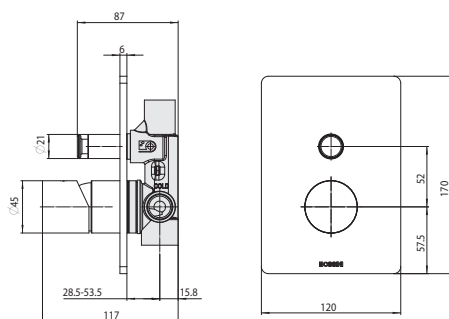
Z00006 PARTI ESTERNE OKI - EXPOSED PARTS

Parti esterne
Exposed parts
Aufputzteile
Parties externes
Partes externas
Детали наружныеДетали наружные

Codice/Code

Finitura/Finish

Z00006

030 cromo/chrome

021 oro/gold

073 nero opaco/mat black

094 nichel sp./satin nickel

Packaging Box: 1 pz/pcs
35x40x25

Universal Single Lever MIXERS

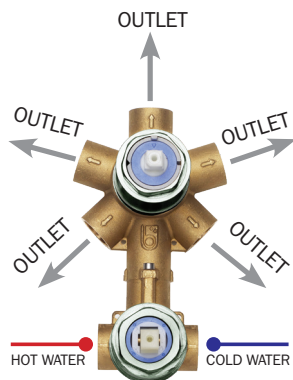
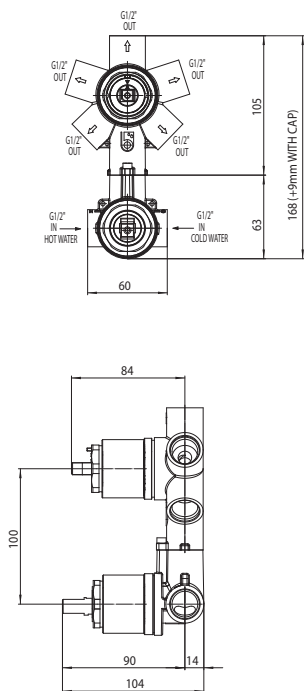

Z00130

Parti incasso miscelatore monocomando universale con deviatore 2-5 vie, attacchi da 1/2", completo di kit di configurazione per 1/2/3/4/5 vie (camme di settaggio e tappi)

Concealed parts for universal single lever mixer with 2-5-ways diverter, 1/2" connections, complete with setting set for 1/2/3/4/5 outlet ways (setting cams and caps)

Unterputz-Einbaukörper für Einhebel Brausebatterie 2 bis 5-Wege einstellbar - Umsteller, 1/2" Anschlüsse und 1/2/3/4/5-Wege Einstellungsset (Einstellungsnocken und Verschlüsse)

Parties à encastrer pour mitigeur mécanique universel avec inverseur 2-5 voies, connexions 1/2" et ensemble de configuration pour 1/2/3/4/5 voies (cames et bouchons)

Partes empotradas para mezclador monocomando universal con desviador 2-5 vías, conexiones 1/2" y set de configuración para 1/2/3/4/5 vías (levas de configuración y tapas)

Встроенная часть однорычажного универсального смесителя с дивертером на 2-5 выхода, подключение 1/2", набор для настройки на 1/2/3/4/5 выхода (кулачковый механизм и заглушки)

Codice/Code

Z00130

Packaging Box: 1 pz/pcs
35x50x35

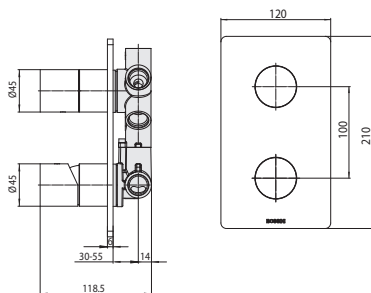

Z00004

Parti esterne miscelatore monocomando 1-5 VIE

Exposed parts for 1-5 WAYS single-lever mixer

Aufputzteile für 1-5-WEGE Einhebel-Brausebatterie

Parties externes pour mitigeur mécanique 1-5 VOIES

Partes externas para mezclador monocomando 1-5 VÍAS

Детали наружные для механического встраиваемого с дивертером 1-5

Codice/Code

Finitura/Finish

Z00004

030 cromo/chrome

021 oro/gold

073 nero opaco/mat black

094 nichel sp./satin nickel

Packaging Box: 1 pz/pcs
35x40x25

Mixers installation ways

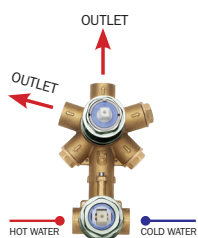

2 WAYS

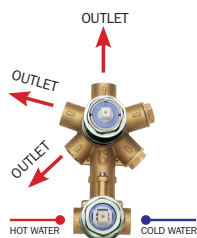

3 WAYS

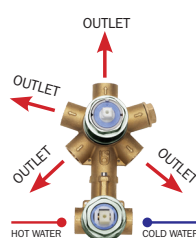

4 WAYS

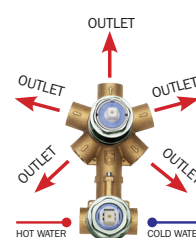

5 WAYS

Universal Thermostatic MIXERS

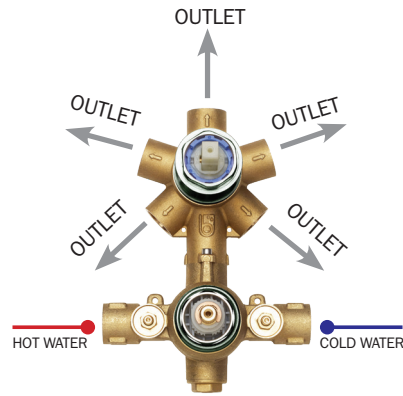
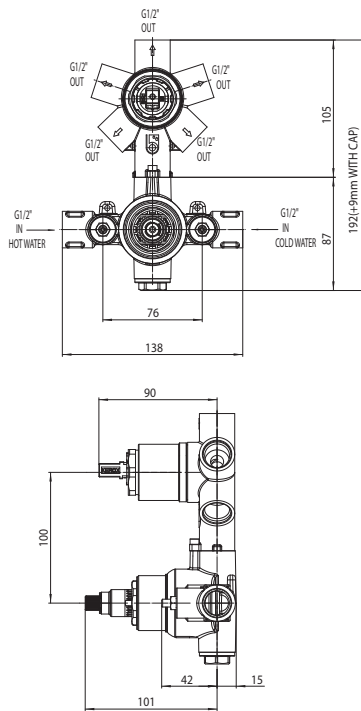

Z00125

Parti incasso miscelatore termostatico universale con deviatore 1-5 vie, attacchi da 1/2", completo di kit di configurazione per 1/2/3/4/5 vie (camme di settaggio e tappi)

Concealed parts for universal thermostatic mixer with 1-5-ways diverter, 1/2" connections, complete with setting set for 1/2/3/4/5 outlet ways (setting cams and caps)

Unterputz-Einbaukörper für Thermostat Brausebatterie 1-bis 5-Wege Umsteller, 1/2" Anschlüsse und 1/2/3/4/5 Wege Einstellungsset (Einstellungsnocken und Verschlüsse)

Parties à encastrer pour mitigeur thermostatique universel avec inverseur 1-5 voies, connexions 1/2" et ensemble de configuration pour 1/2/3/4/5 voies (cames et bouchons)

Partes empotradas para mezclador termostático universal con desviador 1-5 vías, conexiones 1/2" y set de configuración para 1/2/3/4/5 vías (levas de configuración y tapas)

Встроенная часть терmostатического универсального смесителя с дивертером на 1-5 выхода, подключение 1/2", набор для настройки на 1/2/3/4/5 выхода (кулачковый механизм и заглушки)

Codice/Code

Z00125

Packaging Box: 1 pz/pcs
35x50x35

Z00002

Parti esterne miscelatore termostatico 1-5 VIE

Exposed parts for 1-5 WAYS thermostatic mixer

Aufputzteile für 1-5-WEGE Thermostat-Brausebatterie

Parties externes pour mitigeur thermostatique 1-5 VOIES

Partes externas para mezclador termostático 1-5 VÍAS

Детали наружные для терmostатического встраиваемого с дивертером 1-5

Codice/Code

Finitura/Finish

Z00002

030 cromo/chrome

021 oro/gold

073 nero opaco/mat black

094 nichel sp./satin nickel

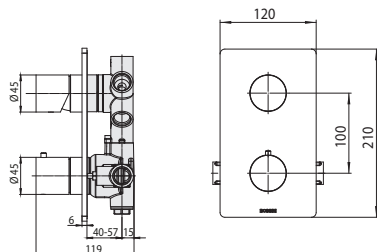

Packaging Box: 1 pz/pcs
35x40x25

Mixers installation ways

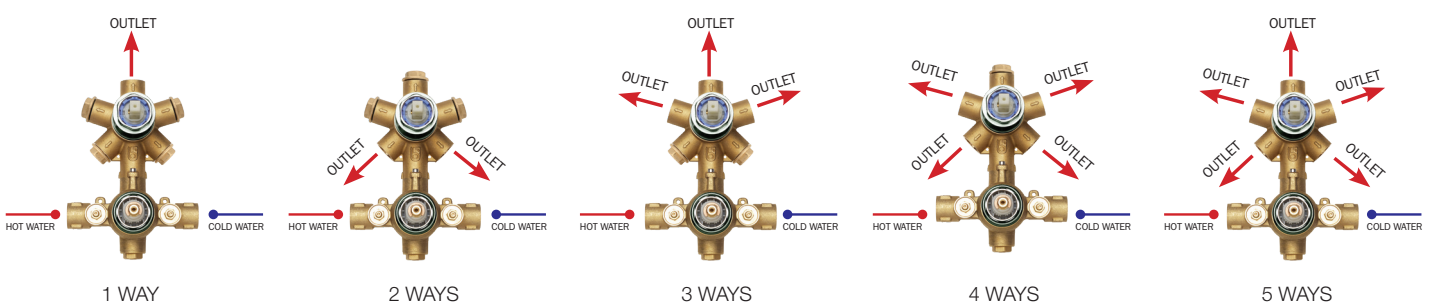



Cube Line

Essenziale design minimalista nella forma squadrata

Essential minimal design in the squared shape

Essentielles Minimal Design der quadratischen Form

Le design minimal essentiel de la forme carrée

El diseño esencial minimalista de la forma cuadrada

Совершенный минимализм квадратных форм

Z004301 LAVABO CUBE

Packaging Box: 8 pz/pcs
25x40x60

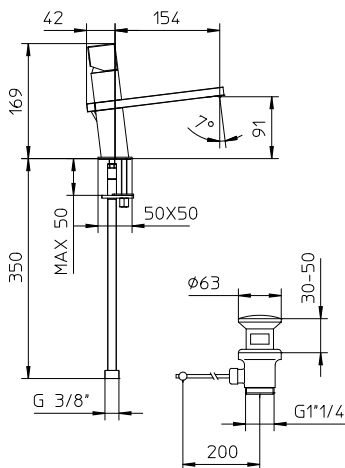

Miscelatore monocomando lavabo con scarico 1"1/4.
Single lever basin mixer with 1"1/4 pop-up waste.
Einhebel Waschtischmischer mit Ablaufgarnitur 1"1/4.
Mitigeur mecanique lavabo avec vidage 1"1/4.
Monomando lavabo con desagüe 1"1/4.
Смеситель для раковины с заглушкой 1"1/4.

Codice/Code Finitura/Finish

Z004301 030 cromo/chrome

021 oro/gold

073 nero opaco/mat black

094 nichel sp./satin nickel

Z004303 LAVABO CUBE

Packaging Box: 8 pz/pcs
25x40x60

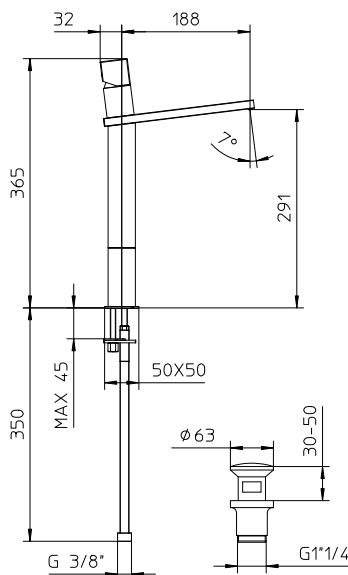

Miscelatore monocomando extra-alto lavabo con scarico 1"1/4.
Extra-high single lever basin mixer with 1"1/4 pop-up waste.
Super-Hoch Einhebel Waschtischmischer mit Ablaufgarnitur 1"1/4.
Mitigeur lavabo mecanique super-haut avec vidage 1"1/4.
Monomando lavabo super-alto con desagüe 1"1/4.
Смеситель для раковины супер-высокий с заглушкой 1"1/4.

Codice/Code Finitura/Finish

Z004303 030 cromo/chrome

021 oro/gold

073 nero opaco/mat black

094 nichel sp./satin nickel

Z004302 LAVABO CUBE

Packaging Box: 8 pz/pcs
25x40x60

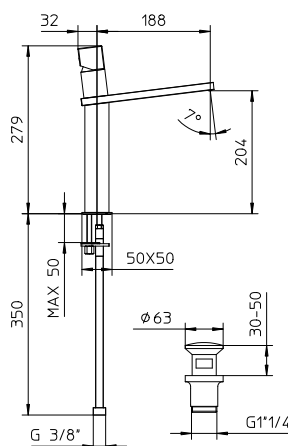

Miscelatore monocomando alto lavabo con scarico 1"1/4.
High single lever basin mixer with 1"1/4 pop-up waste.
Hoch Einhebel Waschtischmischer mit Ablaufgarnitur 1"1/4.
Mitigeur mecanique lavabo haut avec vidage 1"1/4.
Monomando lavabo alto con desagüe 1"1/4.
Смеситель для раковины высокий с заглушкой 1"1/4.

Codice/Code Finitura/Finish

Z004302 030 cromo/chrome

021 oro/gold

073 nero opaco/mat black

094 nichel sp./satin nickel

Z004401 BIDET CUBE



Packaging Box: 8 pz/pcs
25x40x60

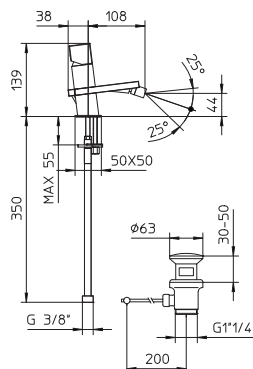

Miscelatore monocomando bidet con scarico 1"1/4.
Single lever bidet mixer with 1"1/4 pop-up waste.
Einhebel Bidetmischer mit Ablaufgarnitur 1"1/4.
Mitigeur de bidet avec vidage 1"1/4.
Monomando bidé con desagüe 1"1/4.
Смеситель для биде с заглушкой 1"1/4.

Codice/Code	Finitura/Finish
Z004401	030 cromo/chrome
	021 oro/gold
	073 nero opaco/mat black
	094 nichel sp./satin nickel

Z004101 VASCA-DOCCIA CUBE

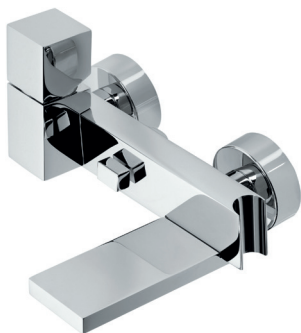

Packaging Box: 8 pz/pcs
25x40x60

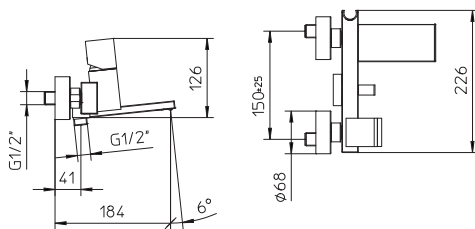

Miscelatore monocomando esterno con deviatore, supporto doccia fisso integrato e attacco flessibile 1/2".

Exposed bath/shower mixer with diverter, fixed shower bracket and 1/2" hose connection.

Einhebel Wannenmischer Aufputz mit Umsteller, Brausehalter und Brauseschlauchanschluss 1/2".

Mitigeur bain douche avec inverseur, support de douche fixe et sortie pour flexible de 1/2".

Monomando baño-ducha con desviador, soporte de ducha fijo y salida por flexible de 1/2".

Смеситель наружный с девиатором, держатель для душевой лейки интегрированный с гибким соединением 1/2".

Codice/Code	Finitura/Finish
Z004101	030 cromo/chrome
	021 oro/gold
	073 nero opaco/mat black
	094 nichel sp./satin nickel

Z004102 DOCCIA MONOCOMANDO ESTERNO CUBE



Packaging Box: 12 pz/pcs
35x50x35

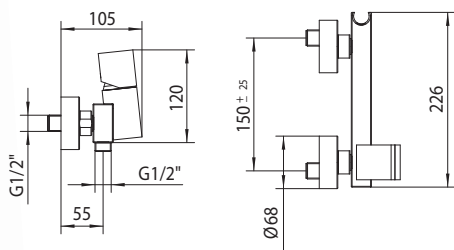

Miscelatore monocomando esterno doccia con uscita da 1/2".

Exposed single lever shower mixer with 1/2" outlet.

Einhebel Brausebatterie Aufputz, Anschluss 1/2".

Mitigeur mécanique de douche avec sortie 1/2".

Monomando ducha con salida de 1/2".

Смеситель наружный для душа с выходом на 1/2".

Codice/Code	Finitura/Finish
Z004102	030 cromo/chrome
	021 oro/gold
	073 nero opaco/mat black
	094 nichel sp./satin nickel

Z004103 DOCCIA TERMOSTATICO ESTERNO CUBE



Packaging Box: 12 pz/pcs
35x50x35

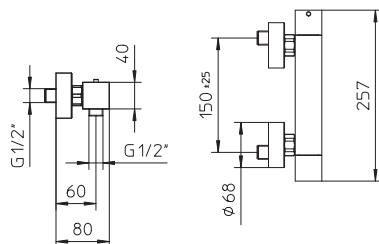

Miscelatore termostatico esterno doccia con uscita da 1/2"

Exposed thermostatic shower mixer with 1/2" outlet

Aufputz Thermostat Brausebatterie mit 1/2" Schlauchanschluss

Mitigeur de douche thermostatique avec connexion flexible 1/2"

Termostático ducha con conexión flexible 1/2"

Наружная душевая группа с выходом на 1/2".

Codice/Code	Finitura/Finish
Z004103	030 cromo/chrome
	021 oro/gold
	073 nero opaco/mat black
	094 nichel sp./satin nickel

Z005357 KIT MISCELATORE TERMOSTATICO 2 VIE - KIT 2 WAYS THERMOSTATIC MIXER

Kit miscelatore termostatico alta portata con deviatore 2 vie, supporto doccia e presa acqua, attacchi da 3/4", doccia CUBE - flessibile ottone doppia aggraffatura cm 150

Shower set consisting of high flow thermostatic mixer with 2-ways diverter, water supply elbow and shower holder, 3/4" connections - CUBE hand shower - double interlock brass hose cm 150

Duschset bestehend aus Hochdurchfluss Thermostat-Mischbatterie mit 2-Wege Umsteller, Brausehalter und Wandanschlussbogen, 3/4" Anschlüsse - Handbrause CUBE - Doppelwicklung Schlauch aus Messing cm 150

Ensemble douche composé par mitigeur thermostatique haut débit avec inverseur 2 voies, sortie murale et support, douchette, connexions 3/4" - douchette CUBE - flexible double agrafage en laiton cm 150

Conjunto ducha con mezclador termostático alta capacidad con desviador 2 vías, soporte ducha con toma de agua, conexión 3/4" - mango ducha CUBE - flexible doble grapado 150 cm

Комплект: смеситель термостатический высокой пропускной способности с девиатором на 2 выхода и держателем с водорозеткой, подключение на 3/4" - ручной душ CUBE - квадратная ручка - гибкий шланг из латуни дв. фальцевания 150 см

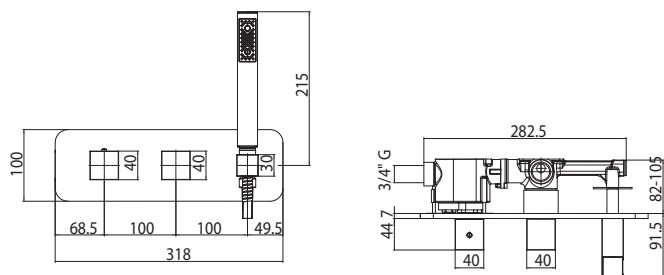

Codice/Code	Finitura/Finish
Z005357	030 cromo/chrome

Z005365 KIT MISCELATORE MONOCOMANDO 2 VIE - KIT 2 WAYS SINGLE LEVER MIXER

Kit miscelatore monocomando con deviatore 2 vie, supporto doccia e presa acqua, attacchi da 1/2" - doccia CUBE - flessibile ottone doppia aggraffatura cm 150

Shower set consisting of single lever mixer with 2-ways diverter, water supply elbow and shower holder, 1/2" connections - CUBE hand shower - double interlock brass hose cm 150

Duschset bestehend aus Einhebel-Mischbatterie mit 2-Wege Umsteller, Brausehalter und Wandanschlussbogen, 1/2" Anschlüsse - Handbrause CUBE - Doppelwicklung Schlauch aus Messing cm 150

Ensemble douche composé par mitigeur mécanique avec inverseur 2 voies, sortie murale et support douchette, connexions 1/2" - douchette CUBE - flexible double agrafage en laiton cm 150

Conjunto ducha con mezclador monocomando con desviador 2 vías, soporte ducha con toma de agua, conexión 1/2" - mango ducha CUBE - flexible doble grapado 150 cm

Комплект: смеситель механический высокой пропускной способности с девиатором на 2 выхода и держателем с водорозеткой, подключение на 1/2" - ручной душ CUBE - квадратная ручка - латунный в.фальцевания - гибкий шланг из латуни дв. фальцевания 150 см

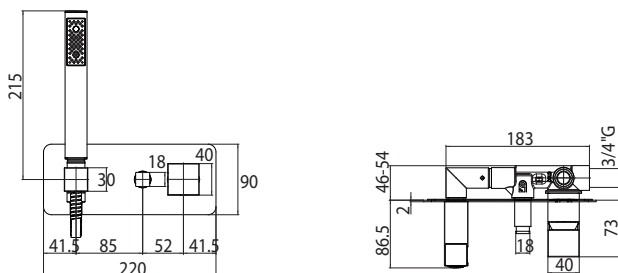

Codice/Code	Finitura/Finish
Z005365	030 cromo/chrome

Z005354 KIT MISCELATORE TERMOSTATICO 2 VIE - KIT 2 WAYS THERMOSTATIC MIXER

Miscelatore termostatico alta portata con deviatore 2 vie, supporto doccia e presa acqua, attacchi da 3/4"

High flow thermostatic mixer with 2-ways diverter and water supply with shower holder, 3/4" connections

Hochdurchfluss Thermostat-Mischbatterie mit 2-Wege Umsteller und Brausehalter mit Wandanschlussbogen, 3/4" Anschlüsse

Mitigeur thermostatique haut débit avec inverseur 2 voies et sortie murale avec support douchette, connexions 3/4"

Mezclador termostático de alta capacidad con desviador de 2 vías, soporte ducha con toma de agua, conexiones de 3/4"

Смеситель термостатический высокой пропускной способности с девиатором на 2 выхода и держателем с водорозеткой, подключение на 3/4"

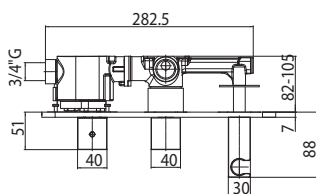
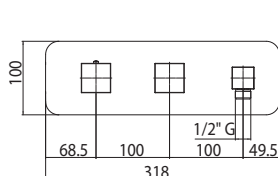
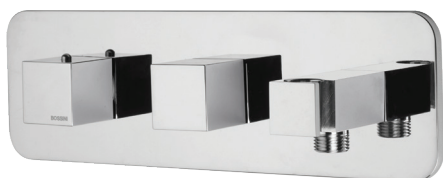

Codice/Code

Finitura/Finish

Z005354

030 cromo/chrome

Z005363 KIT MISCELATORE MONOCOMANDO 2 VIE - KIT 2 WAYS SINGLE LEVER MIXER

Miscelatore monocomando con deviatore 2 vie, supporto doccia e presa acqua, attacchi da 1/2"

Single lever mixer with 2-ways diverter and water supply with shower holder, 1/2" connections

Unterputz-Einbaukörper für Einhebelbatterie mit 2-Wege Umsteller und Brausehalter mit Wandanschlussbogen, 1/2" Anschlüsse

Mitigeur mécanique avec inverseur 2 voies et sortie murale avec support douchette, connexions 1/2"

Mezclador monomando con desviador de 2 vías, soporte ducha con toma de agua, conexiones 1/2"

Смеситель механический с девиатором на 2 выхода и держатель с водорозеткой, соединение на 1/2"

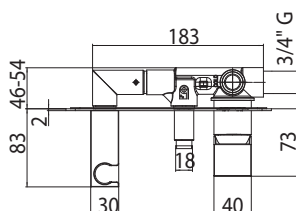
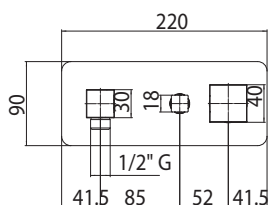

Codice/Code

Finitura/Finish

Z005363

030 cromo/chrome



Z00007 INCASSO MONOCOMANDO 1 VIA - 1 WAY SINGLE LEVER CONCEALED PART

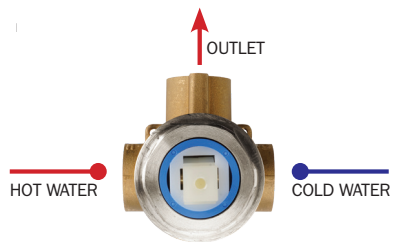
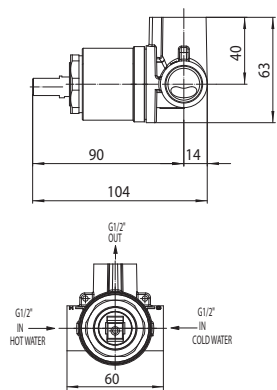

Parti incasso miscelatore monocomando 1 VIA, attacco da 1/2"
 Concealed parts for single lever mixer 1 WAY, 1/2" connection
 Unterputz-Einbaukörper für Einhebelbatterie, 1/2" Anschluss
 Parties à encastrer pour mitigeur mécanique 1 VOIE, connexion 1/2"
 Partes de empotrado mezclador monomando de 1 VÍA, conexión 1/2"
 Смеситель механический встраиваемый с девиатором 1 направления 1/2"

Packaging Box: 1 pz/pcs
 35x40x25

Codice/Code Uscite/Outlets

Z00007 1

Z00064 PARTI ESTERNE CUBE - EXPOSED PARTS

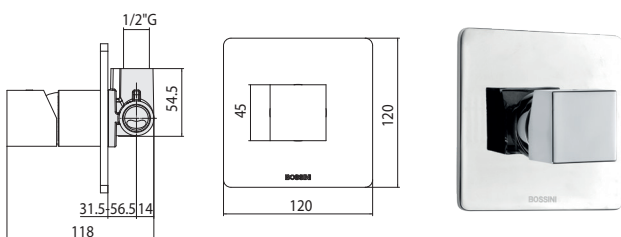

Parti esterne
 Exposed parts
 Aufputzteile
 Parties externes
 Partes externas
 Детали наружные/Детали наружные

Codice/Code Finitura/Finish

Z00064 030 cromo/chrome

021 oro/gold

073 nero opaco/mat black

094 nichel sp./satin nickel

Packaging Box: 1 pz/pcs
 35x40x25

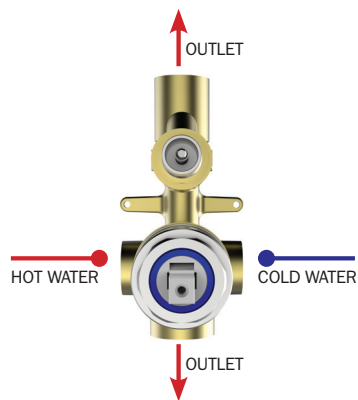
Z00005 INCASSO MONOCOMANDO 2 VIE - 2 WAY SINGLE LEVER CONCEALED PART

Parti incasso miscelatore monocomando con deviatore 2 VIE, attacchi da 1/2"

Concealed parts for single lever mixer with 2-WAYS diverter, 1/2" connections

Unterputz-Einbaukörper für Einhebelbatterie mit 2-WEGE Umsteller, 1/2" Anschlüsse

Parties à encastrer pour mitigeur mécanique avec inverseur 2 VOIES, connexions 1/2"

Partes de empotrado para mezclador monomando con desviador de 2 VIAS, conexiones 1/2"

Смеситель механический встраиваемый с девиатором 2 направления 1/2"

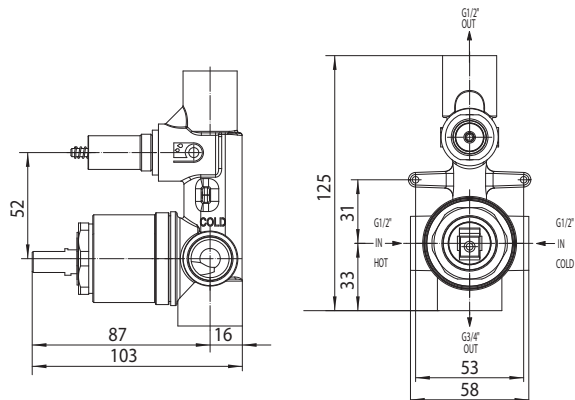

Packaging Box: 1 pz/pcs
35x40x25

Codice/Code

Uscite/Outlets

Z00005

2

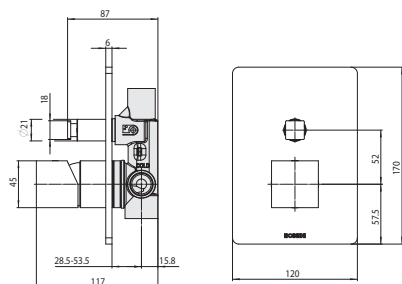
Z00063 PARTI ESTERNE CUBE - EXPOSED PARTS

Parti esterne
Exposed parts
Aufputzteile
Parties externes
Partes externas
Детали наружныеДетали наружные

Codice/Code

Finitura/Finish

Z00063

030 cromo/chrome

021 oro/gold

073 nero opaco/mat black

094 nichel sp./satin nickel

Packaging Box: 1 pz/pcs
35x40x25

Universal Single Lever MIXERS

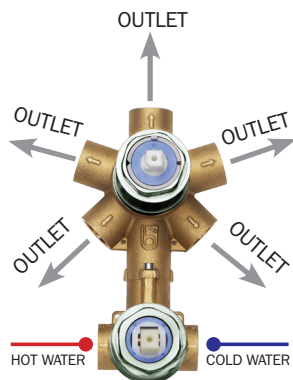
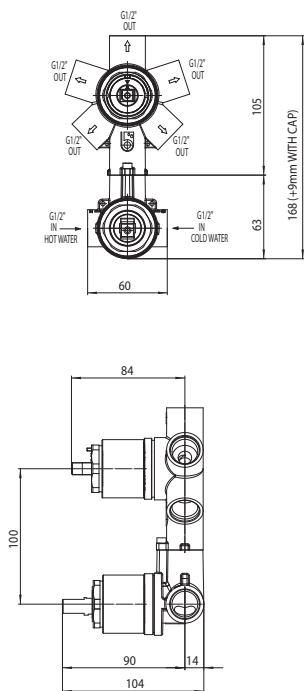

Z00130

Parti incasso miscelatore monocomando universale con deviatore 2-5 vie, attacchi da 1/2", completo di kit di configurazione per 1/2/3/4/5 vie (camme di settaggio e tappi)

Concealed parts for universal single lever mixer with 2-5-ways diverter, 1/2" connections, complete with setting set for 1/2/3/4/5 outlet ways (setting cams and caps)

Unterputz-Einbaukörper für Einhebel Brausebatterie 2 bis 5-Wege einstellbar - Umsteller, 1/2" Anschlüsse und 1/2/3/4/5-Wege Einstellungsset (Einstellungsnocken und Verschlüsse)

Parties à encastrer pour mitigeur mécanique universel avec inverseur 2-5 voies, connexions 1/2" et ensemble de configuration pour 1/2/3/4/5 voies (cames et bouchons)

Partes empotradas para mezclador monocomando universal con desviador 2-5 vías, conexiones 1/2" y set de configuración para 1/2/3/4/5 vías (levas de configuración y tapas)

Встроенная часть однорычажного универсального смесителя с дивертером на 2-5 выхода, подключение 1/2", набор для настройки на 1/2/3/4/5 выхода (кулачковый механизм и заглушки)

Codice/Code

Z00130

Packaging Box: 1 pz/pcs
35x50x35

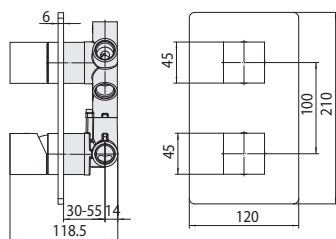

Z00062

Parti esterne miscelatore monocomando 1-5 VIE

Exposed parts for 1-5 WAYS single-lever mixer

Aufputzteile für 1-5-WEGE Einhebel-Brausebatterie

Parties externes pour mitigeur mécanique 1-5 VOIES

Partes externas para mezclador monocomando 1-5 VÍAS

Детали наружные для механического встраиваемого с дивертером 1-5

Codice/Code

Finitura/Finish

Z00062

030 cromo/chrome

021 oro/gold

073 nero opaco/mat black

094 nichel sp./satin nickel

Packaging Box: 1 pz/pcs
35x40x25

Mixers installation ways

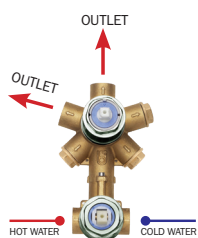

2 WAYS

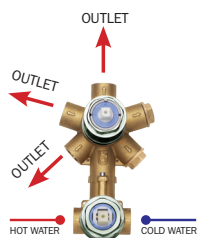

3 WAYS

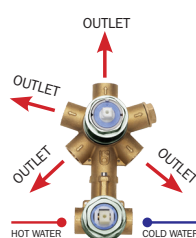

4 WAYS

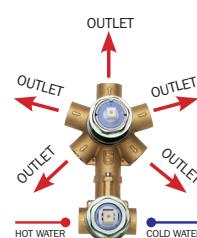

5 WAYS

Universal Thermostatic MIXERS

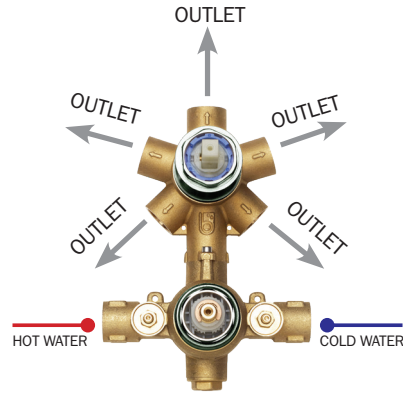
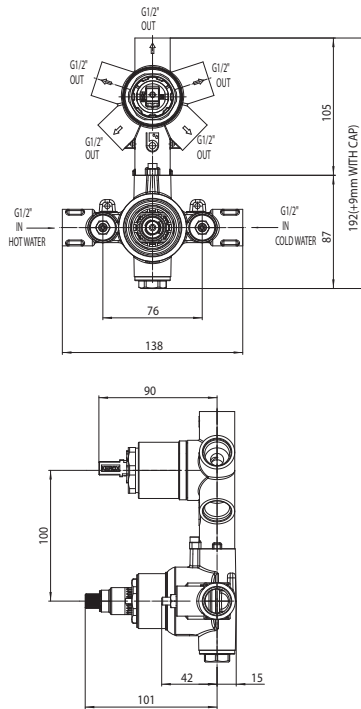

Z00125

Parti incasso miscelatore termostatico universale con deviatore 1-5 vie, attacchi da 1/2", completo di kit di configurazione per 1/2/3/4/5 vie (camme di settaggio e tappi)

Concealed parts for universal thermostatic mixer with 1-5-ways diverter, 1/2" connections, complete with setting set for 1/2/3/4/5 outlet ways (setting cams and caps)

Unterputz-Einbaukörper für Thermostat Brausebatterie 1-bis 5-Wege Umsteller, 1/2" Anschlüsse und 1/2/3/4/5 Wege Einstellungsset (Einstellungsnocken und Verschlüsse)

Parties à encastrer pour mitigeur thermostatique universel avec inverseur 1-5 voies, connexions 1/2" et ensemble de configuration pour 1/2/3/4/5 voies (cames et bouchons)

Partes empotradas para mezclador termostático universal con desviador 1-5 vías, conexiones 1/2" y set de configuración para 1/2/3/4/5 vías (levas de configuración y tapas)

Встроенная часть терmostатического универсального смесителя с дивертером на 1-5 выхода, подключение 1/2", набор для настройки на 1/2/3/4/5 выхода (кулачковый механизм и заглушки)

Codice/Code

Z00125

Packaging Box: 1 pz/pcs
35x50x35

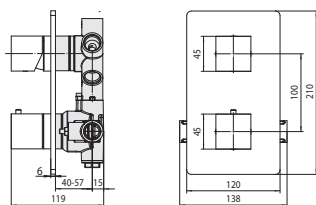

Z00061

Parti esterne miscelatore termostatico 1-5 VIE

Exposed parts for 1-5 WAYS thermostatic mixer

Aufputzteile für 1-5-WEGE Thermostat-Brausebatterie

Parties externes pour mitigeur thermostatique 1-5 VOIES

Partes externas para mezclador termostático 1-5 VÍAS

Детали наружные для терmostатического встраиваемого с дивертером 1-5

Codice/Code

Finitura/Finish

Z00061

030 cromo/chrome

021 oro/gold

073 nero opaco/mat black

094 nichel sp./satin nickel

Packaging Box: 1 pz/pcs
35x40x25

Mixers installation ways

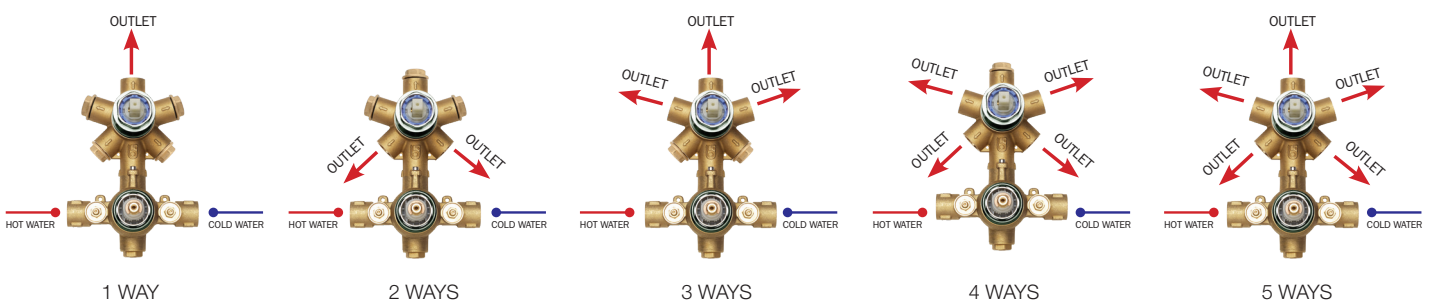

1 WAY

2 WAYS

3 WAYS

4 WAYS

5 WAYS



Liberty Line

La sintesi fra tradizione e tecnologia

Where tradition and technology meet

Die Synthese zwischen Tradition und Technologie

L'union entre la tradition et la technologie

El punto de encuentro entre la tradición y la tecnología

Синтез традиции и технологии

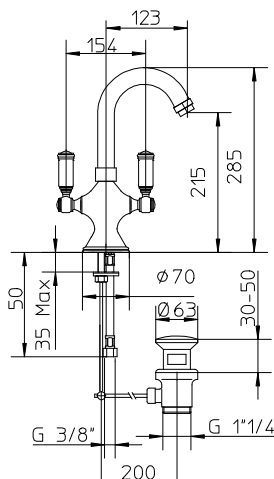
Z001301 LAVABO LIBERTY

Packaging Box: 8 pz/pcs
25x40x60

Monoforo lavabo con bocca girevole e scarico 1"1/4.
Single hole wash basin mixer with swivel spout and 1"1/4 pop-up waste.
1-Loch Waschtischarmatur mit Rohrauslauf und Ablaufgarnitur 1"1/4.
Mélangeur de lavabo avec bec mobile et vidage 1"1/4.
Monobloc lavabo con caño giratorio y desagüe 1"1/4.
Смеситель для раковины с поворотным изливом и заглушкой 1"1/4.

Codice/Code	Finitura/Finish
Z001301	030 cromo/chrome
	021 oro/gold
	094 nichel sp./satin nickel
	022 ottone antico/antique brass

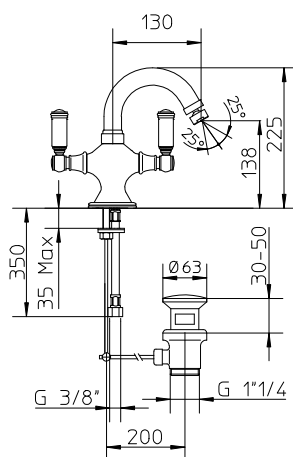
Z001401 BIDET LIBERTY

Packaging Box: 8 pz/pcs
25x40x60

Monoforo bidet con bocca girevole e scarico 1"1/4.
Single hole bidet mixer with 1"1/4 pop-up waste.
1-Loch Bidetarmatur mit Ablaufgarnitur 1"1/4.
Mélangeur de bidet avec vidage 1"1/4.
Monobloc bidé con caño giratorio y desagüe 1"1/4.
Смеситель для биде с поворотным изливом и заглушкой 1"1/4.

Codice/Code	Finitura/Finish
Z001401	030 cromo/chrome
	021 oro/gold
	094 nichel sp./satin nickel
	022 ottone antico/antique brass

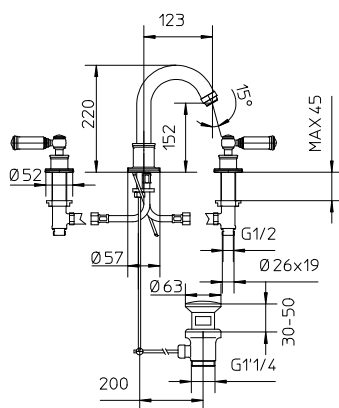
Z001302 LAVABO LIBERTY

Packaging Box: 8 pz/pcs
25x40x60

Batteria lavabo a tre fori con bocca girevole e scarico 1"1/4.
3-hole wash basin mixer with swivel spout and 1"1/4 pop-up waste.
3-Loch Waschtischarmatur mit Rohrauslauf und Ablaufgarnitur 1"1/4.
Mélangeur de lavabo à trois trous avec bec mobile et vidage 1"1/4.
Grupo lavabo 3 agujeros con caño giratorio y desagüe 1"1/4.
Комплект для раковины на 3 отверстия с поворотным изливом и заглушкой 1"1/4.

Codice/Code	Finitura/Finish
Z001302	030 cromo/chrome
	021 oro/gold
	094 nichel sp./satin nickel
	022 ottone antico/antique brass

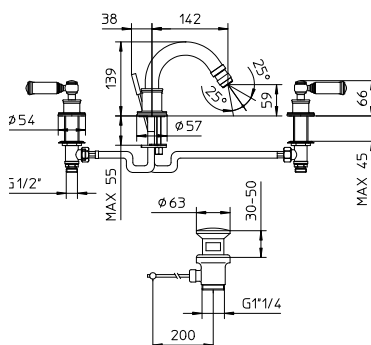
Z001402 BIDET LIBERTY

Packaging Box: 8 pz/pcs
25x40x60

Batteria bidet a tre fori con bocca girevole e scarico 1"1/4.
3-hole bidet mixer with swivel spout and 1"1/4 pop-up waste.
3-Loch Bidetarmatur mit Rohrauslauf und Ablaufgarnitur 1"1/4.
Mélangeur de bidet à trois trous avec bec mobile et vidage 1"1/4.
Grupo bidé 3 agujeros con caño giratorio y desagüe 1"1/4.
Комплект для биде на 3 отверстия с поворотным изливом и заглушкой 1"1/4.

Codice/Code	Finitura/Finish
Z001402	030 cromo/chrome
	021 oro/gold
	094 nichel sp./satin nickel
	022 ottone antico/antique brass

Z001403 BIDET LIBERTY

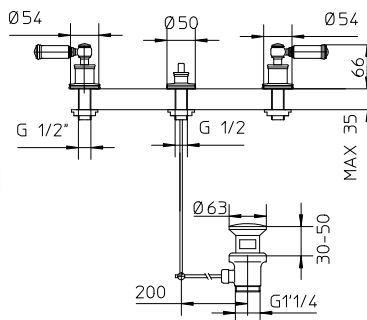

Batteria bidet a tre fori con scarico 1"1/4.
3-hole bidet mixer with 1"1/4 pop-up waste.
3-Loch Bidetarmatur mit Ablaufgarnitur 1"1/4.
Batterie de bidet à trois trous avec vidage 1"1/4.
Grupo bidé 3 agujeros con desagüe 1"1/4.
Комплект для биде на 3 отверстия с заглушкой 1"1/4.

Codice/Code Finitura/Finish

Z001403 030 cromo/chrome

021 oro/gold

094 nichel sp./satin nickel

022 ottone antico/antique brass

Packaging Box: 8 pz/pcs
25x40x60

Z001303 LAVABO LIBERTY

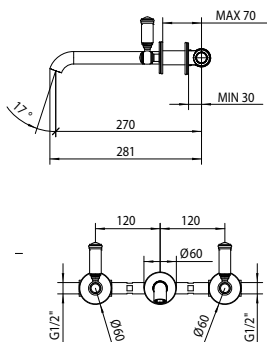

Batteria lavabo incasso a 3 fori senza scarico.
3-hole concealed wash basin mixer without waste.
3-Loch Wandarmatur für Waschtisch ohne Ablaufgarnitur.
Mélangeur mural à trois trous de lavabo sans vidage.
Grupo lavabo 3 agujeros mural sin desagüe.
Комплект для раковины на 3 отверстия
встраиваемый без заглушки.

Codice/Code Finitura/Finish

Z001303 030 cromo/chrome

021 oro/gold

094 nichel sp./satin nickel

022 ottone antico/antique brass

Packaging Box: 8 pz/pcs
25x40x60

Z000301

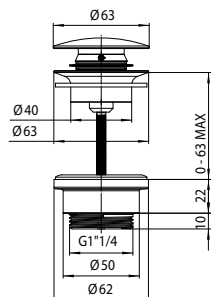

Piletta di scarico Clic Clac 1" 1/4
1" 1/4 Click Clack waste
Ablaufventil Click-Clack 1" 1/4
Vidage Clic Clac 1" 1/4
Válvula desague Click Clack 1" 1/4
Сливом Clic-Clac 1" 1/4

Codice/Code Finitura/Finish

Z000301 030 cromo/chrome

021 oro/gold

094 nichel sp./satin nickel

022 ottone antico/antique brass

Packaging Box: 8 pz/pcs
25x40x60

Z001103 VASCA LIBERTY

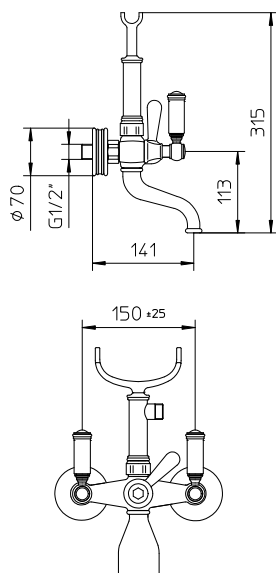

Gruppo esterno vasca con deviatore, doccia Liberty-Gom, flessibile
ottone doppia aggraffatura cm 150.

Exposed bath mixer with diverter, Liberty-Gom handshower, double
interlock brass hose cm 150.

Zweihebel Wannenarmatur mit Umstell lung, Liberty-Gom
Handbrause, Doppelwicklung Brauseschlauch cm 150.

Mélangeur de bain avec inverseur, douchette Liberty-Gom et
flexible double agrafage cm 150.

Grupo baño con desviador, mango ducha Liberty-Gom y flexible de
doble grapado cm 150.

Комплект наружный для ванной с переключателем,
лейка Liberty-Gom, шланг из латуни дв. фальцевания 150 см.

Codice/Code Finitura/Finish

Z001103 030 cromo/chrome

021 oro/gold

094 nichel sp./satin nickel

022 ottone antico/antique brass

Packaging Box: 8 pz/pcs
25x40x60

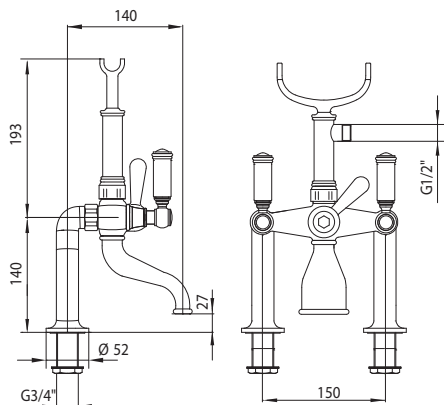
Z001106 BORDO VASCA LIBERTY

Gruppo esterno 2 fori soprabordo vasca con deviatore, doccia Liberty-Gom, flessibile ottone doppia aggraffatura cm 150.

Two-hole deck mounted bath mixer with diverter, Liberty-Gom handshower, double interlock brass hose cm 150.

Zweihebel Wannenumarmatur für Wannenumrandmontage, mit Umstellung, Liberty-Gom Handbrause, Doppelwicklung Brauseschlauch cm 150.

Mélangeur bain-douche sur gorge avec inverseur, douchette Liberty-Gom et flexible double agrafage cm 150.

Grupo baño-ducha sobre repisa con desviador, mango ducha Liberty y flexible de doble grapado cm 150.

Комплект для установки на борт ванной 2 отверстия с переключателем, лейка Liberty -Gom, шланг из латуни дв. фальцевания 150 см.

Codice/Code	Finitura/Finish
Z001106	030 cromo/chrome
	021 oro/gold
	094 nichel sp./satin nickel
	022 ottone antico/antique brass

Packaging Box: 8 pz/pcs
25x40x60

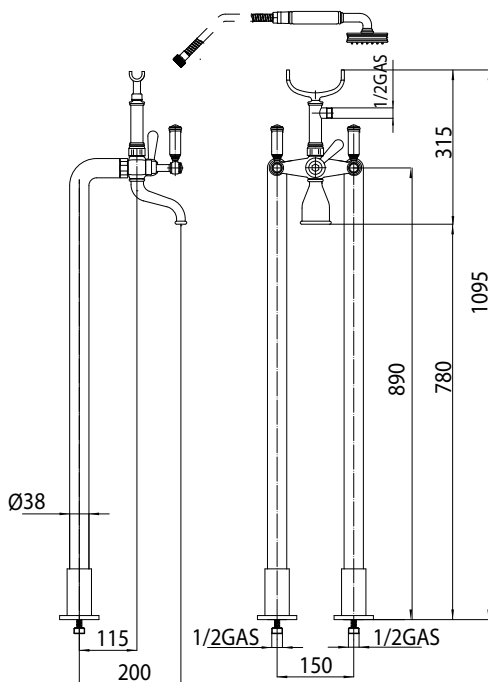
L00130 VASCA ESTERNO LIBERTY

Gruppo vasca esterno con colonne a pavimento 1/2" altezza 890 mm, Doccia Liberty-Gom, flessibile ottone doppia aggraffatura cm 150.

Free standing bath-shower mixer with floor legs 1/2" height 890 mm, Liberty-Gom handshower and double interlock brass hose, cm 150.

Wannenbatterie Montage auf dem Boden mit Standfüßen 1/2", Höhe 890 mm, Liberty-Gom Handbrause und Doppelwicklung Brauseschlauch cm 150.

Mélangeur bain-douche avec colonnettes alimentation par le sol 1/2", hauteur 890 mm, Douchette Liberty-Gom et flexible double agrafage cm 150.

Grupo baño exterior con columnas a pavimento 1/2" altura 890 mm, mango ducha Liberty-Gom y flexible de doble grapado cm 150.

Наружная группа для ванной с колоннами, крепление в пол - 1/2" высота 890 мм, Душевая лейка Liberty-Gom и шланг дв. фальцевание латунь, 150 см 1/2" FF.

Codice/Code	Finitura/Finish
L00130	030 cromo/chrome
	021 oro/gold
	094 nichel sp./satin nickel
	022 ottone antico/antique brass

Packaging Box: 1 pz/pcs
26x115x16

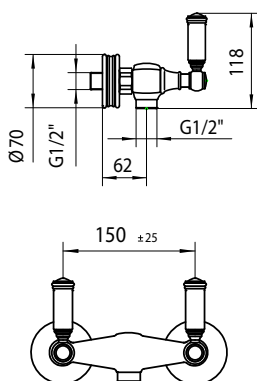
Z001101 DOCCIA ESTERNO LIBERTY

Gruppo esterno doccia con uscita da 1/2".

Exposed shower mixer with 1/2" outlet.

Zweihebel Brausenarmatur, Anschluss 1/2".

Mélangeur de douche avec sortie 1/2".

Grupo ducha con salida de 1/2".

Наружная душевая группа с выходом на 1/2".

Codice/Code	Finitura/Finish
Z001101	030 cromo/chrome
	021 oro/gold
	094 nichel sp./satin nickel
	022 ottone antico/antique brass

Packaging Box: 8 pz/pcs
25x40x60





Z00007 INCASSO MONOCOMANDO 1 VIA - 1 WAY SINGLE LEVER CONCEALED PART

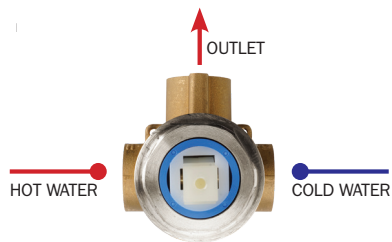
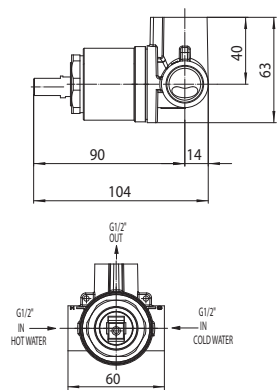

Parti incasso miscelatore monocomando 1 VIA, attacco da 1/2"
 Concealed parts for single lever mixer 1 WAY, 1/2" connection
 Unterputz-Einbaukörper für Einhebelbatterie, 1/2" Anschluss
 Parties à encastrer pour mitigeur mécanique 1 VOIE, connexion 1/2"
 Partes de empotrado mezclador monomando de 1 VÍA, conexión 1/2"
 Смеситель механический встраиваемый с девиатором 1 направления 1/2"

Packaging Box: 1 pz/pcs
 35x40x25

Codice/Code Uscite/Outlets

Z00007 1

Z00067 PARTI ESTERNE LIBERTY - EXPOSED PARTS

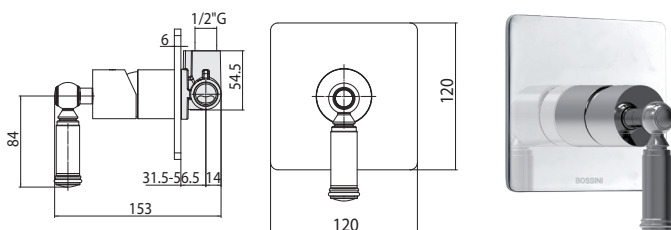

Packaging Box: 1 pz/pcs
 35x40x25

Parti esterne
 Exposed parts
 Aufputzteile
 Parties externes
 Partes externas
 Детали наружные/Детали наружные

Codice/Code Finitura/Finish

Z00067 030 cromo/chrome

021 oro/gold

094 nichel sp./satin nickel

022 ottone antico/antique brass

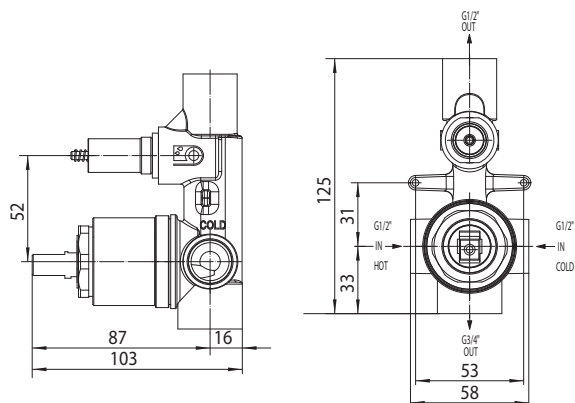
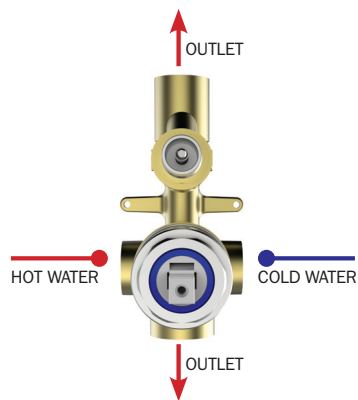
Z00005 INCASSO MONOCOMANDO LIBERTY 2 VIE - 2 WAY SINGLE LEVER CONCEALED PART

Parti incasso miscelatore monocomando con deviatore 2 VIE, attacchi da 1/2"

Concealed parts for single lever mixer with 2-WAYS diverter, 1/2" connections

Unterputz-Einbaukörper für Einhebelbatterie mit 2-WEGE Umsteller, 1/2" Anschlüsse

Parties à encastrer pour mitigeur mécanique avec inverseur 2 VOIES, connexions 1/2"

Partes de empotrado para mezclador monomando con desviador de 2 VIAS, conexiones 1/2"

Смеситель механический встраиваемый с девиатором 2 направления 1/2"

Packaging Box: 1 pz/pcs
35x40x25

Codice/Code

Uscite/Outlets

Z00005

2

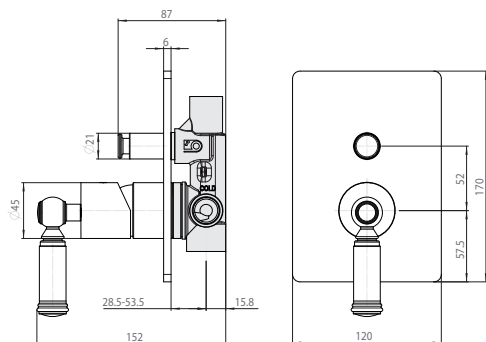
Z00066 PARTI ESTERNE LIBERTY - EXPOSED PARTS

Parti esterne
Exposed parts
Aufputzteile
Parties externes
Partes externas
Детали наружные

Codice/Code

Finitura/Finish

Z00066

030 cromo/chrome

021 oro/gold

094 nichel sp./satin nickel

022 ottone antico/antique brass

Packaging Box: 1 pz/pcs
35x40x25

Universal Single Lever MIXERS

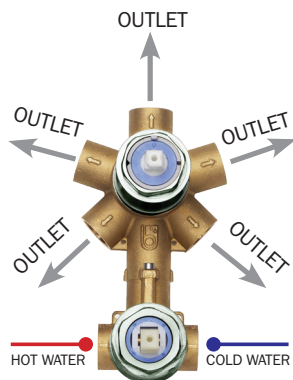
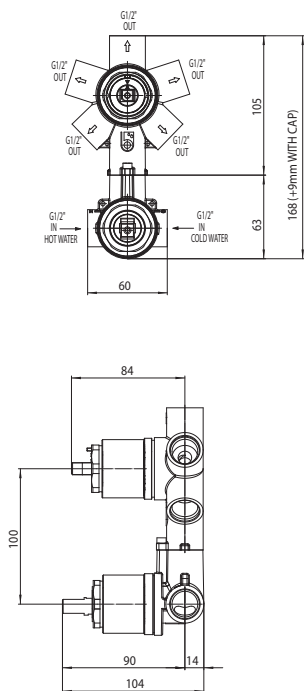

Z00130

Parti incasso miscelatore monocomando universale con deviatore 2-5 vie, attacchi da 1/2", completo di kit di configurazione per 1/2/3/4/5 vie (cammie di settaggio e tappi)

Concealed parts for universal single lever mixer with 2-5-ways diverter, 1/2" connections, complete with setting set for 1/2/3/4/5 outlet ways (setting cams and caps)

Unterputz-Einbaukörper für Einhebel Brausebatterie 2 bis 5-Wege einstellbar - Umsteller, 1/2" Anschlüsse und 1/2/3/4/5-Wege Einstellungsset (Einstellungsnocken und Verschlüsse)

Parties à encastrer pour mitigeur mécanique universel avec inverseur 2-5 voies, connexions 1/2" et ensemble de configuration pour 1/2/3/4/5 voies (cames et bouchons)

Partes empotradas para mezclador monocomando universal con desviador 2-5 vías, conexiones 1/2" y set de configuración para 1/2/3/4/5 vías (levas de configuración y tapas)

Встроенная часть однорычажного универсального смесителя с дивертером на 2-5 выхода, подключение 1/2", набор для настройки на 1/2/3/4/5 выхода (кулачковый механизм и заглушки)

Codice/Code

Z00130

Packaging Box: 1 pz/pcs
35x50x35

Z00065

Parti esterne miscelatore monocomando 1-5 VIE

Exposed parts for 1-5 WAYS single-lever mixer

Aufputzteile für 1-5-WEGE Einhebel-Brausebatterie

Parties externes pour mitigeur mécanique 1-5 VOIES

Partes externas para mezclador monocomando 1-5 VÍAS

Детали наружные для механического встраиваемого с дивертером 1-5

Codice/Code

Finitura/Finish

Z00065

030 cromo/chrome

021 oro/gold

094 nichel sp./satin nickel

022 ottone antico/antique brass

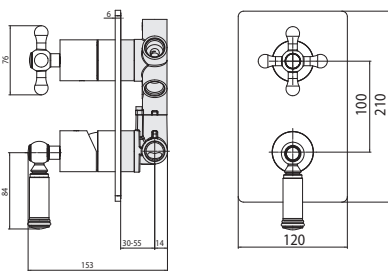

Packaging Box: 1 pz/pcs
35x40x25

Mixers installation ways

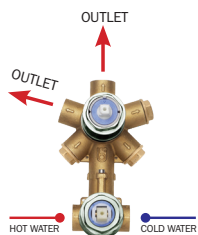

2 WAYS

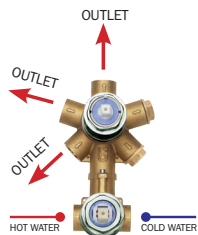

3 WAYS

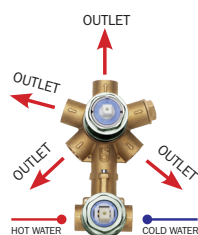

4 WAYS

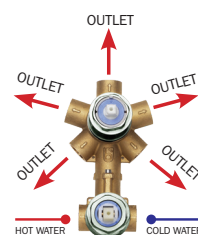

5 WAYS

Universal Thermostatic MIXERS

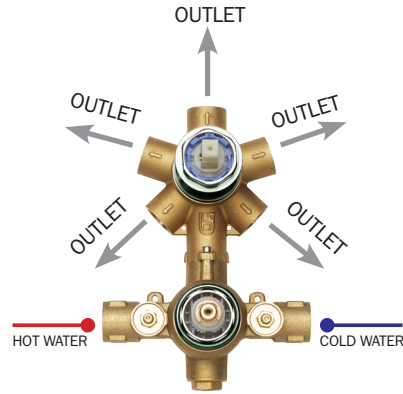
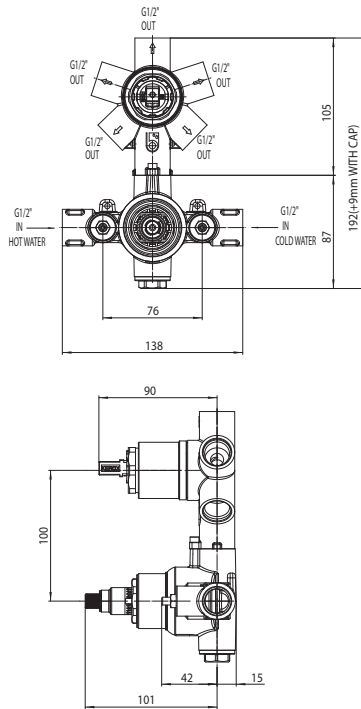

Z00125

Parti incasso miscelatore termostatico universale con deviatore 1-5 vie, attacchi da 1/2", completo di kit di configurazione per 1/2/3/4/5 vie (camme di settaggio e tappi)

Concealed parts for universal thermostatic mixer with 1-5-ways diverter, 1/2" connections, complete with setting set for 1/2/3/4/5 outlet ways (setting cams and caps)

Unterputz-Einbaukörper für Thermostat Brausebatterie 1-bis 5-Wege Umsteller, 1/2" Anschlüsse und 1/2/3/4/5 Wege Einstellungsset (Einstellungsnocken und Verschlüsse)

Parties à encastrer pour mitigeur thermostatique universel avec inverseur 1-5 voies, connexions 1/2" et ensemble de configuration pour 1/2/3/4/5 voies (cames et bouchons)

Partes empotradas para mezclador termostático universal con desviador 1-5 vías, conexiones 1/2" y set de configuración para 1/2/3/4/5 vías (levas de configuración y tapas)

Встроенная часть терmostатического универсального смесителя с дивертером на 1-5 выхода, подключение 1/2", набор для настройки на 1/2/3/4/5 выхода (кулачковый механизм и заглушки)

Codice/Code

Z00125

Packaging Box: 1 pz/pcs
35x50x35

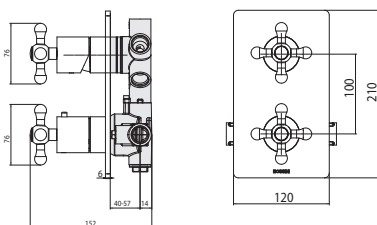

Z00068

Parti esterne miscelatore termostatico 1-5 VIE

Exposed parts for 1-5 WAYS thermostatic mixer

Aufputzteile für 1-5-WEGE Thermostat-Brausebatterie

Parties externes pour mitigeur thermostatique 1-5 VOIES

Partes externas para mezclador termostático 1-5 VÍAS

Детали наружные для терmostатического встраиваемого с дивертером 1-5

Codice/Code

Z00068

Finitura/Finish

030 cromo/chrome

021 oro/gold

094 nichel sp./satin nickel

022 ottone antico/antique brass

Packaging Box: 1 pz/pcs
35x40x25

Mixers installation ways

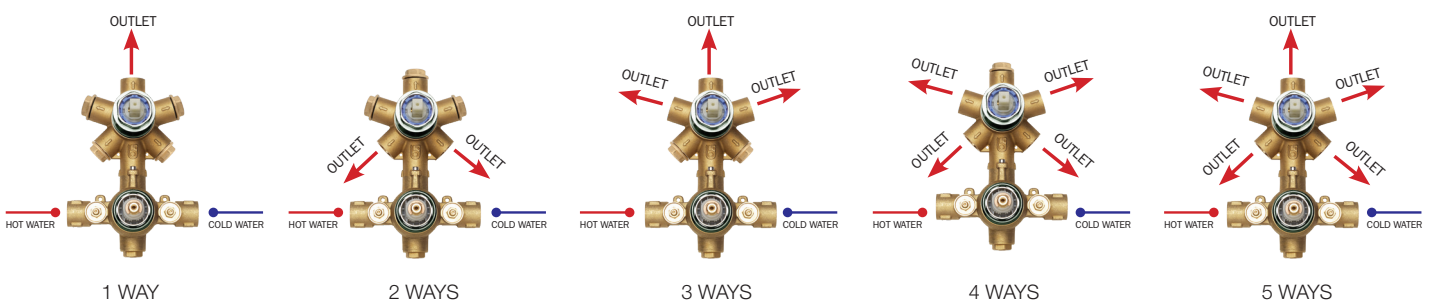



Acciaio Inox Line

Stainless Steel Collection

Edelstahl Kollektion

Collection Acier Inoxydable

Colección Acero Inoxidable

Коллекция из нержавеющей стали

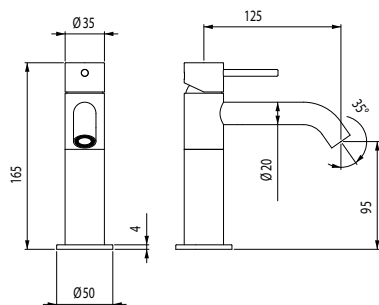
INZ006 LAVABO INOX

Miscelatore monocomando lavabo con scarico 1"1/4.
 Single lever basin mixer with 1"1/4 pop-up waste.
 Einhebel Waschtischmischer mit Ablaufgarnitur 1"1/4.
 Mitigeur lavabo vidage 1"1/4.
 Monomando lavabo con desagüe 1"1/4.
 Смеситель для раковины с заглушкой 1"1/4.

Packaging Box: 5 pz/pcs
 35x50x35

Codice/Code	Finitura/Finish
INZ006	030 Acciaio Lucido/Polished Stainless Steel
	075 Acciaio Satinato/Matt Stainless Steel

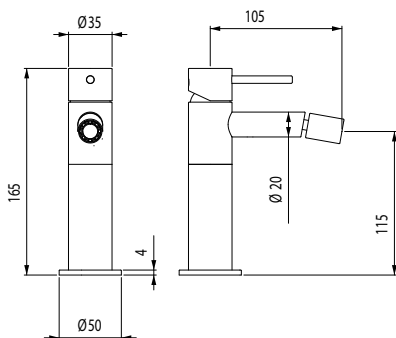
INZ007 BIDET INOX

Miscelatore monocomando alto lavabo con scarico 1"1/4.
 High single lever basin mixer with 1"1/4 pop-up waste.
 Hoch Einhebel Waschtischmischer mit Ablaufgarnitur 1"1/4.
 Mitigeur lavabo haut avec vidage 1"1/4.
 Monomando lavabo alto con desagüe 1"1/4.
 Смеситель для раковины высокий с заглушкой 1"1/4.

Packaging Box: 8 pz/pcs
 35x50x35

Codice/Code	Finitura/Finish
INZ007	030 Acciaio Lucido/Polished Stainless Steel
	075 Acciaio Satinato/Matt Stainless Steel

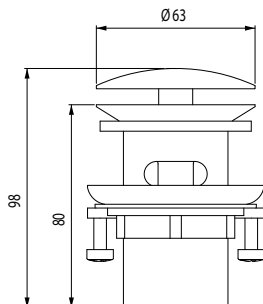
INZ008 INOX POP-UP

Piletta di scarico automatica 1"1/4.
 1"1/4 pop-up waste.
 Automatisches Ablaufventil 1"1/4.
 Vidage automatique 1"1/4.
 Desagüe automático 1"1/4.
 Слив автоматический 1"1/4.

Packaging Box: 8 pz/pcs
 25x40x60

Codice/Code	Finitura/Finish
INZ008	030 Acciaio Lucido/Polished Stainless Steel
	075 Acciaio Satinato/Matt Stainless Steel



Z00007 INCASSO MONOCOMANDO 1 VIA - 1 WAY SINGLE LEVER CONCEALED PART

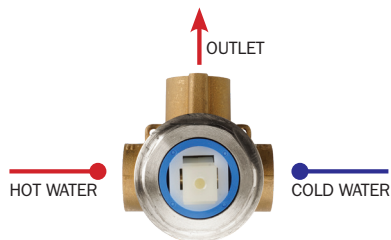
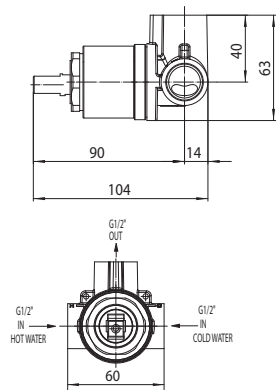

Parti incasso miscelatore monocomando 1 VIA, attacco da 1/2"

Concealed parts for single lever mixer 1 WAY, 1/2" connection

Unterputz-Einbaukörper für Einhebelbatterie, 1/2" Anschluss

Parties à encastrer pour mitigeur mécanique 1 VOIE, connexion 1/2"

Partes de empotrado mezclador monocomando de 1 VÍA, conexión 1/2"

Смеситель механический встраиваемый с девиатором 1 направления 1/2"

Packaging Box: 1 pz/pcs
35x40x25

Codice/Code

Z00007

INZ047 PARTI ESTERNE INOX - EXPOSED PARTS

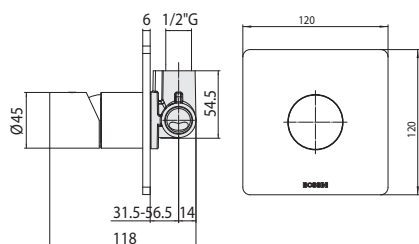

Parti esterne

Exposed parts

Aufputzteile

Parties externes

Partes externas

Детали наружные/Детали наружные

Codice/Code

Finitura/Finish

INZ047

030 Acciaio Lucido/Polished Stainless Steel

075 Acciaio Satinato/Matt Stainless Steel

Packaging Box: 1 pz/pcs
35x40x25

Universal Single Lever MIXERS

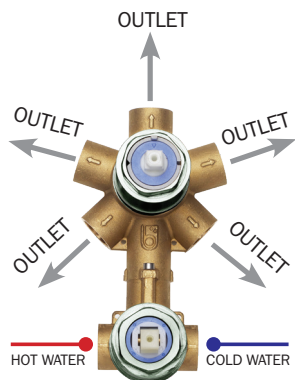
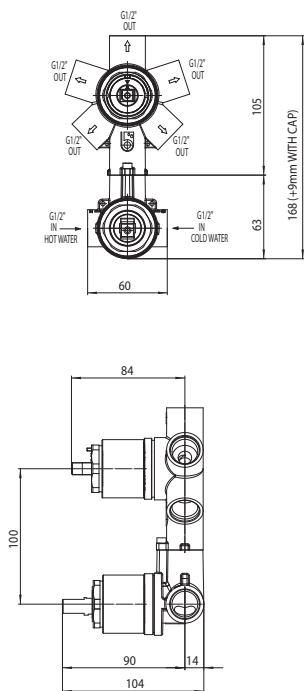

Z00130

Parti incasso miscelatore monocomando universale con deviatore 2-5 vie, attacchi da 1/2", completo di kit di configurazione per 1/2/3/4/5 vie (camme di settaggio e tappi)

Concealed parts for universal single lever mixer with 2-5-ways diverter, 1/2" connections, complete with setting set for 1/2/3/4/5 outlet ways (setting cams and caps)

Unterputz-Einbaukörper für Einhebel Brausebatterie 2 bis 5-Wege einstellbar - Umsteller, 1/2" Anschlüsse und 1/2/3/4/5-Wege Einstellungsset (Einstellungsnocken und Verschlüsse)

Parties à encastrer pour mitigeur mécanique universel avec inverseur 2-5 voies, connexions 1/2" et ensemble de configuration pour 1/2/3/4/5 voies (cames et bouchons)

Partes empotradas para mezclador monocomando universal con desviador 2-5 vías, conexiones 1/2" y set de configuración para 1/2/3/4/5 vías (levas de configuración y tapas)

Встроенная часть однорычажного универсального смесителя с дивертером на 2-5 выхода, подключение 1/2", набор для настройки на 1/2/3/4/5 выхода (кулачковый механизм и заглушки)

Codice/Code

Z00130

Packaging Box: 1 pz/pcs
35x50x35

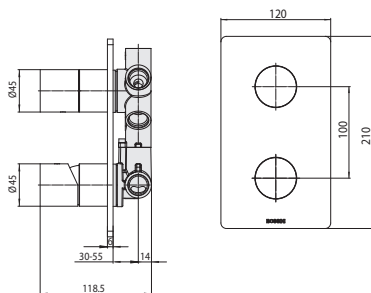

INZ042

Parti esterne miscelatore monocomando 1-5 VIE

Exposed parts for 1-5 WAYS single-lever mixer

Aufputzteile für 1-5-WEGE Einhebel-Brausebatterie

Parties externes pour mitigeur mécanique 1-5 VOIES

Partes externas para mezclador monocomando 1-5 VÍAS

Детали наружные для механического встраиваемого с дивертером 1-5

Codice/Code

Finitura/Finish

INZ042

030 Acciaio Lucido/Polished Stainless Steel

075 Acciaio Sat./Matt Stainless Steel

Packaging Box: 1 pz/pcs
35x40x25

Mixers installation ways

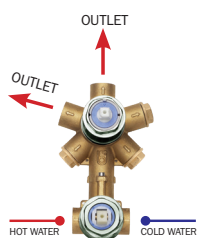

2 WAYS

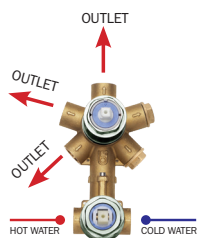

3 WAYS

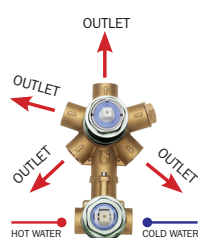

4 WAYS

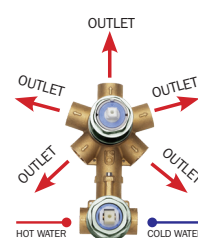

5 WAYS

Universal Thermostatic MIXERS

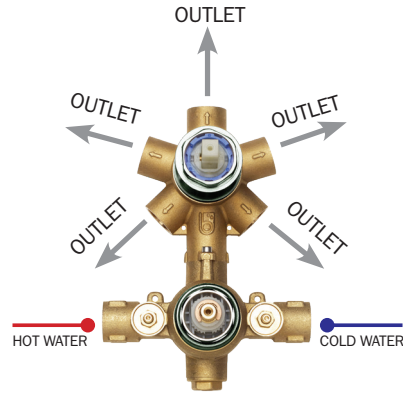
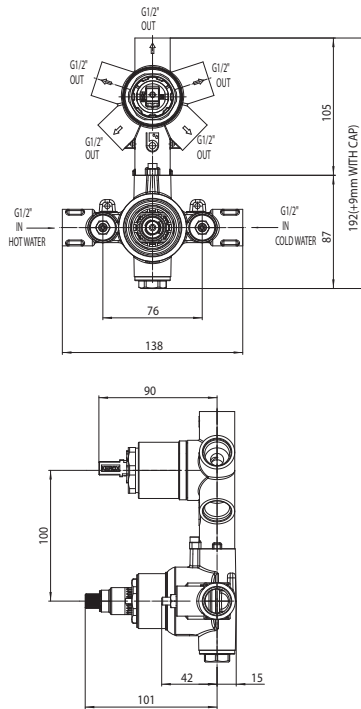

Z00125

Parti incasso miscelatore termostatico universale con deviatore 1-5 vie, attacchi da 1/2", completo di kit di configurazione per 1/2/3/4/5 vie (camme di settaggio e tappi)

Concealed parts for universal thermostatic mixer with 1-5-ways diverter, 1/2" connections, complete with setting set for 1/2/3/4/5 outlet ways (setting cams and caps)

Unterputz-Einbaukörper für Thermostat Brausebatterie 1-bis 5-Wege Umsteller, 1/2" Anschlüsse und 1/2/3/4/5 Wege Einstellungsset (Einstellungsnocken und Verschlüsse)

Parties à encastrer pour mitigeur thermostatique universel avec inverseur 1-5 voies, connexions 1/2" et ensemble de configuration pour 1/2/3/4/5 voies (cames et bouchons)

Partes empotradas para mezclador termostático universal con desviador 1-5 vías, conexiones 1/2" y set de configuración para 1/2/3/4/5 vías (levas de configuración y tapas)

Встроенная часть терmostатического универсального смесителя с дивертером на 1-5 выхода, подключение 1/2", набор для настройки на 1/2/3/4/5 выхода (кулачковый механизм и заглушки)

Codice/Code

Z00125

Packaging Box: 1 pz/pcs
35x50x35

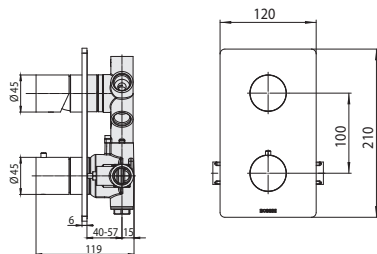

INZ003

Parti esterne miscelatore termostatico 1-5 VIE

Exposed parts for 1-5 WAYS thermostatic mixer

Aufputzteile für 1-5-WEGE Thermostat-Brausebatterie

Parties externes pour mitigeur thermostatique 1-5 VOIES

Partes externas para mezclador termostático 1-5 VÍAS

Детали наружные для терmostатического встраиваемого с дивертером 1-5

Codice/Code

Finitura/Finish

INZ003

030 Acciaio Lucido/Polished

075 Acciaio Sat./Matt Stainless Steel

Packaging Box: 1 pz/pcs
35x40x25

Mixers installation ways

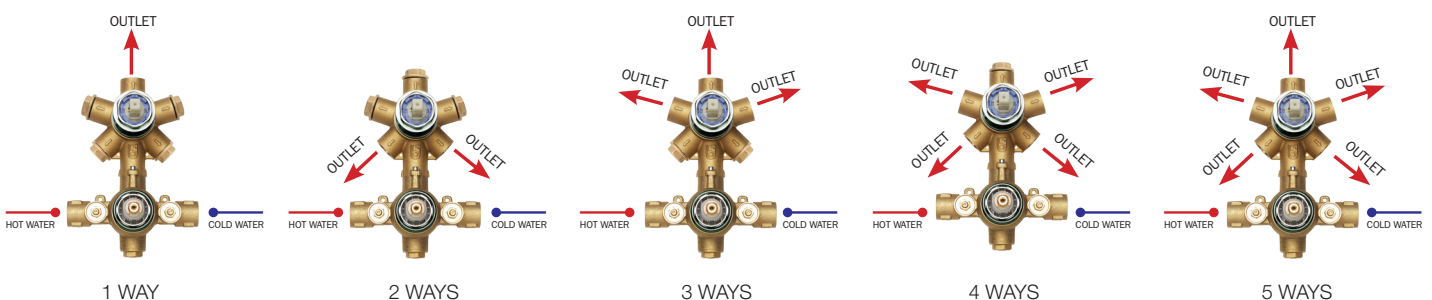

PIASTRA INTERA
SINGLE BACK PLATE

PIASTRE INDIVIDUALI
INDIVIDUAL PLATES



Rectangular



Oki



Cube



Miscelatori Termostatici Alta portata

High flow thermostatic mixers

Hochdurchfluss Thermostat-Mischbatterie

Mitigeurs thermostatiques haut débit

Mezcladores termostáticos alta capacidad

Термостатические Смесители/ Высокой Пропускной Способности

Z030204000 Miscelatori Termostatici Alta Portata - 1 USCITA / OUTLET

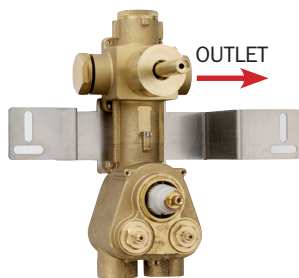

Parti incasso per miscelatore termostatico alta portata a 1 USCITA con valvola on-off e attacchi da 3/4". Installazione orizzontale o verticale

Concealed parts for high-flow 1 OUTLET thermostatic mixer with stop valve and 3/4" connections. Horizontal or vertical installation

Unterputz-Einbaukörper für 1 AUSGANG Hochdurchfluss Thermostat-Mischbatterie mit Stoppventil und 3/4" Verbindungen. Waagrecht- oder Senkrechteinbau

Parties à encastrer pour mitigeur thermostatique haut débit 1 SORTIE avec robinet d'arrêt et connexions 3/4". Installation en vertical ou en horizontal.

Partes empotradas para mezclador termostático alta capacidad 1 SALIDA con llave de paso y conexiones 3/4". Instalación horizontal o vertical.

Детали, встроенного монтажа, для терmostатического смесителя, высокой пропускной способности на 3/4", установка вертикальная/горизонтальная на 1 ВЫХОД

LP LOW PRESSURE - HIGH FLOW



Codice/Code

Z030204000

Packaging Box: 1 pz/pcs
27x26x28

PIASTRA INTERA - Single back plate



Z031202

Z033202

Z032202

Piastra intera per installazione orizzontale o verticale.

Exposed single back plate vertical/horizontal installation

Aufputzteile mit Waagrecht- oder Senkrechteinbau Vollplatte

Plaque multi-éléments pour installation horizontale ou verticale

Placa entera para instalación horizontal o vertical

Установка вертикальная/горизонтальная для терmostатического смесителя

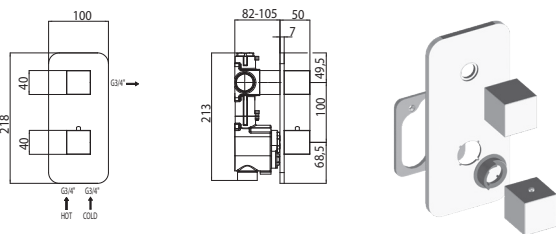

Codice/Code

Finitura/Finish

Z031202 030 cromo/chrome

Z033202 030 cromo/chrome

Z032202 030 cromo/chrome

PIASTRE INDIVIDUALI - Individual plates



Z031201

Z033201

Z032201

Piastrre singole per installazione orizzontale o verticale

Exposed individual plates with vertical/horizontal installation

Aufputzteile mit Waagrecht- oder Senkrechteinbau Einzelplatten

Plaques individuelles pour installation horizontale ou verticale

Placas individuales para instalación horizontal o vertical

Установка вертикальная/горизонтальная для терmostатического смесителя

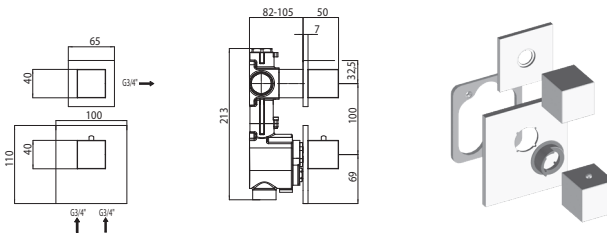

Codice/Code

Finitura/Finish

Z031201 030 cromo/chrome

Z033201 030 cromo/chrome

Z032201 030 cromo/chrome

Packaging Box: 1 pz/pcs
21x7x49

Packaging Box: 1 pz/pcs
26x6x27

Z030205000 Miscelatori Termostatici Alta Portata - 2 USCITE / OUTLETS

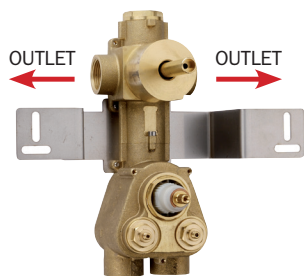

Parti incasso per miscelatore termostatico alta portata a 2 USCITE con deviatore 2 vie e attacchi da 3/4". Installazione orizzontale o verticale

Concealed parts for high-flow 2 OUTLETS thermostatic mixer with 2-ways diverter and 3/4" connections. Horizontal or vertical installation

Unterputz-Einbaukörper für 2 AUSGÄNGE Hochdurchfluss Thermostat-Mischbatterie mit 2-Wege Umsteller und 3/4" Verbindungen. Waagrecht- oder Senkrechteinbau

Parties à encastrer pour mitigeur thermostatique haut débit 2 SORTIES avec inverseur 2 voies et connexions 3/4". Installation en vertical ou en horizontal.

Partes empotradas para mezclador termostático alta capacidad 2 SALIDAS con desviador 2 vías y conexiones 3/4". Instalación horizontal o vertical.

Codice/Code

Z030205000

Packaging Box: 1 pz/pcs
27x26x28

Детали, встроенного монтажа, для термостатического смесителя, высокой пропускной способности на 3/4", С ДЕВИАТОРОМ НА 2 НАПРАВЛЕНИЯ, установка вертикальная/горизонтальная

HP HIGH PRESSURE - HIGH FLOW



PIASTRA INTERA - Single back plate



Z031202

Z033202

Z032202

Piastra intera per installazione orizzontale o verticale.

Exposed single back plate vertical/horizontal installation

Aufputzteile mit Waagrecht- oder Senkrechteinbau Vollplatte

Plaque multi-éléments pour installation horizontale ou verticale

Placa entera para instalación horizontal o vertical

Установка вертикальная/горизонтальная для термостатического смесителя

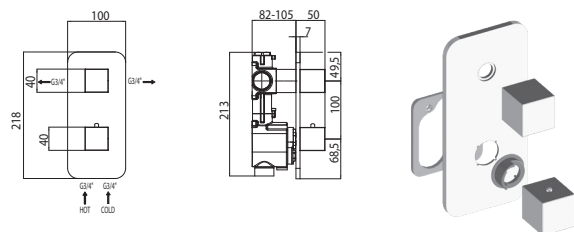

PIASTRE INDIVIDUALI - Individual plates



Z031201

Z033201

Z032201

Piastre singole per installazione orizzontale o verticale

Exposed individual plates with vertical/horizontal installation

Aufputzteile mit Waagrecht- oder Senkrechteinbau Einzelplatten

Plaques individuelles pour installation horizontale ou verticale

Placas individuales para instalación horizontal o vertical

Установка вертикальная/горизонтальная для термостатического смесителя

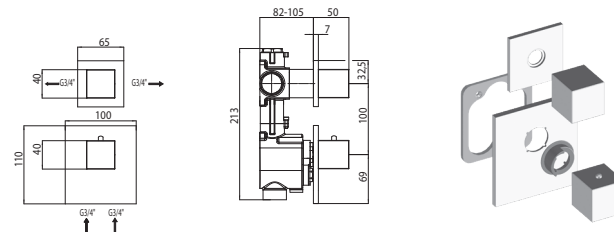

Codice/Code Finitura/Finish

Z031202 030 cromo/chrome

Z033202 030 cromo/chrome

Z032202 030 cromo/chrome

Codice/Code Finitura/Finish

Z031201 030 cromo/chrome

Z033201 030 cromo/chrome

Z032201 030 cromo/chrome

Packaging Box: 1 pz/pcs
21x7x49

Packaging Box: 1 pz/pcs
26x6x27

Z030201000 Miscelatori Termostatici Alta Portata - 2 USCITE / OUTLETS

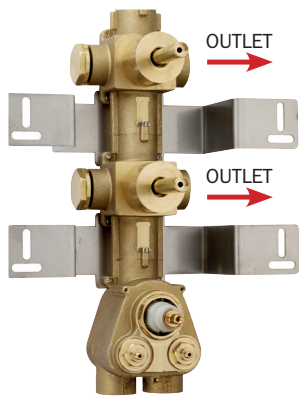

Parti incasso per miscelatore termostatico alta portata a 2 USCITE con 2 valvole on-off e attacchi da 3/4". Installazione orizzontale o verticale

Concealed parts for high-flow 2 OUTLETS thermostatic mixer with 2 stop valves and 3/4" connections. Horizontal or vertical installation

Unterputz-Einbaukörper für 2 AUSGÄNGE Hochdurchfluss Thermostat-Mischbatterie mit 2 Stoppventile und 3/4" Verbindungen. Waagrecht- oder Senkrechtinbau

Parties à encastrer pour mitigeur thermostatique haut débit 2 SORTIES avec 2 robinets d'arrêt et connexions 3/4". Installation en vertical ou en horizontal.

Partes empotradas para mezclador termostático alta capacidad 2 SALIDAS con 2 llaves de paso y conexiones 3/4". Instalación horizontal o vertical.

Детали наружные, для терmostатического смесителя высокой пропускной способности на 3/4", установка вертикальная/горизонтальная 2 ВЫХОДА.

Codice/Code

Z030201000

Packaging Box: 1 pz/pcs
27,5x18,5x51,5

LP LOW PRESSURE - HIGH FLOW



PIASTRA INTERA - Single back plate



Z031204

Z033204

Z032204

Piastra intera per installazione orizzontale o verticale.
Exposed single back plate vertical/horizontal installation
Aufputzteile mit Waagrecht- oder Senkrechtinbau Vollplatte
Plaque multi-éléments pour installation horizontale ou verticale
Placa entera para instalación horizontal o vertical
Установка вертикальная/горизонтальная для терmostатического смесителя

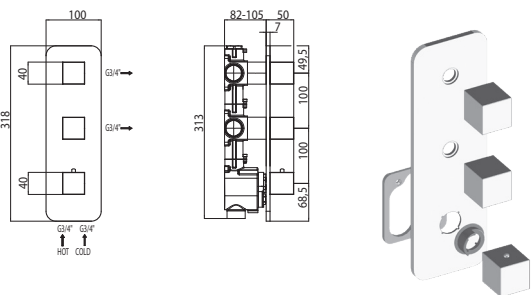

Codice/Code Finitura/Finish

Z031204 030 cromo/chrome

Z033204 030 cromo/chrome

Z032204 030 cromo/chrome

Packaging Box: 1 pz/pcs
21x7x49

PIASTRE INDIVIDUALI - Individual plates



Z031203

Z033203

Z032203

Piastrre singole per installazione orizzontale o verticale
Exposed individual plates with vertical/horizontal installation
Aufputzteile mit Waagrecht- oder Senkrechtinbau Einzelplatten
Plaques individuelles pour installation horizontale ou verticale
Placas individuales para instalación horizontal o vertical
Установка вертикальная/горизонтальная для терmostатического смесителя

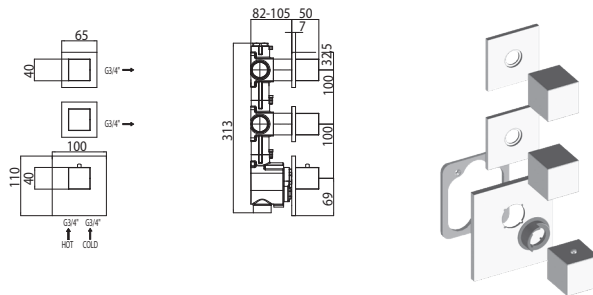

Codice/Code Finitura/Finish

Z031203 030 cromo/chrome

Z033203 030 cromo/chrome

Z032203 030 cromo/chrome

Packaging Box: 1 pz/pcs
26x6x27

Z030203000 Miscelatori Termostatici Alta Portata - 3 USCITE / OUTLETS

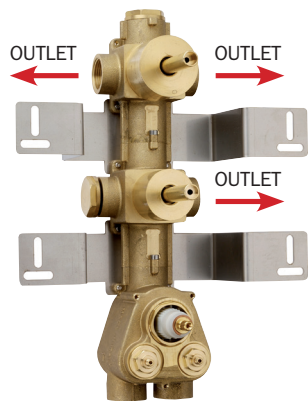

OUTLET ← → OUTLET



OUTLET →



OUTLET →

Parti incasso per miscelatore termostatico alta portata a 3 USCITE con 1 deviatore 2 vie, 1 valvola on-off e attacchi da 3/4". Installazione orizzontale o verticale

Concealed parts for high-flow 3 OUTLETS thermostatic mixer with 1 2-ways diverter, 1 stop valve and 3/4" connections. Horizontal or vertical installation

Unterputz-Einbaukörper für 3 AUSGÄNGE Hochdurchfluss Thermostat-Mischbatterie mit 1 2-Wege Umsteller, 1 Stoppventil und 3/4" Verbindungen. Waagrecht- oder Senkrechteinbau

Parties à encastrer pour mitigeur thermostatique haut débit 3 SORTIES avec 1 inverseur 2 voies, 1 robinet d'arrêt et connexions 3/4". Installation en vertical ou en horizontal.

Partes empotradas para mezclador termostático alta capacidad de 3 SALIDAS con 1 desviador 2 vías, 1 llave paso y conexiones 3/4". Instalación horizontal o vertical.

Детали, встроенного монтажа, для термостатического смесителя, высокой пропускной способности на 3/4", на 3 ВЫХОДА (С ДЕВИАТОРОМ 2 НАПРАВЛЕНИЯ и запорным вентилем), установка вертикальная/горизонтальная

HP HIGH PRESSURE - HIGH FLOW



Codice/Code

Z030203000

Packaging Box: 1 pz/pcs
27,5x18,5x51,5

PIASTRA INTERA - Single back plate



Z031204

Z033204

Z032204

Piastra intera per installazione orizzontale o verticale.

Exposed single back plate vertical/horizontal installation

Aufputzteile mit Waagrecht- oder Senkrechteinbau Vollplatte

Plaque multi-éléments pour installation horizontale ou verticale

Placa entera para instalación horizontal o vertical

Установка вертикальная/горизонтальная для термостатического смесителя

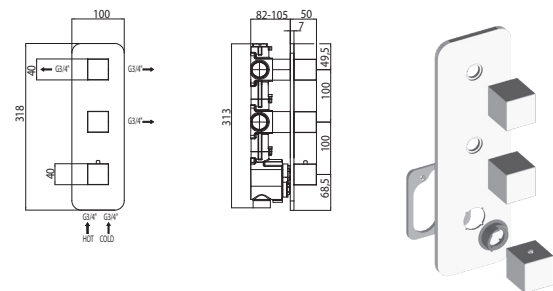

PIASTRE INDIVIDUALI - Individual plates



Z031203

Z033203

Z032203

Piastre singole per installazione orizzontale o verticale

Exposed individual plates with vertical/horizontal installation

Aufputzteile mit Waagrecht- oder Senkrechteinbau Einzelplatten

Plaques individuelles pour installation horizontale ou verticale

Placas individuales para instalación horizontal o vertical

Установка вертикальная/горизонтальная для термостатического смесителя

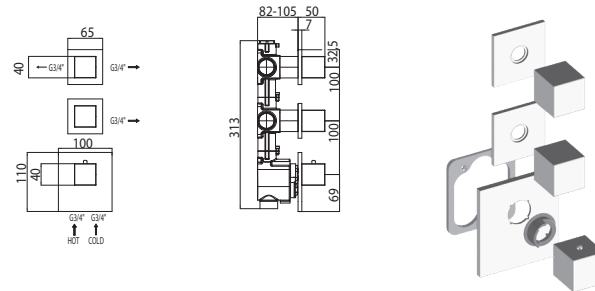

Codice/Code Finitura/Finish

Z031204 030 cromo/chrome

Z033204 030 cromo/chrome

Z032204 030 cromo/chrome

Codice/Code Finitura/Finish

Z031203 030 cromo/chrome

Z033203 030 cromo/chrome

Z032203 030 cromo/chrome

Packaging Box: 1 pz/pcs
21x7x49

Packaging Box: 1 pz/pcs
26x6x27

Z030202000 Miscelatori Termostatici Alta Portata - 3 USCITE / OUTLETS

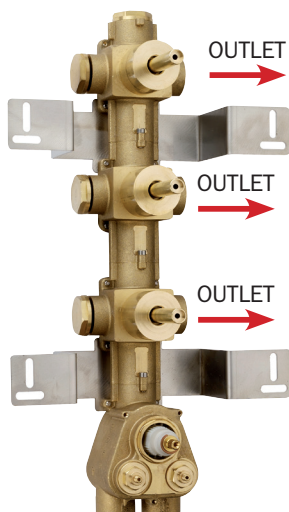

Parti incasso per miscelatore termostatico alta portata a 3 USCITE con 3 valvole on-off e attacchi da 3/4". Installazione orizzontale o verticale

Concealed parts for high-flow 3 OUTLETS thermostatic mixer with 3 stop valves and 3/4" connections. Horizontal or vertical installation

Unterputz-Einbaukörper für 3 AUSGÄNGE Hochdurchfluss Thermostat-Mischbatterie mit 3 Stoppventile und 3/4" Verbindungen. Waagrecht- oder Senkrechteinbau

Parties à encastrer pour mitigeur thermostatique haut débit 3 SORTIES avec 3 robinets d'arrêt et connexions 3/4". Installation en vertical ou en horizontal.

Partes empotradas para mezclador termostático alta capacidad 3 SALIDAS con 3 llaves de paso y conexiones 3/4". Instalación horizontal o vertical.

Детали, встроенного монтажа, для термостатического смесителя, высокой пропускной способности на 3/4", установка вертикальная/горизонтальная на 3 ВЫХОДА

LP LOW PRESSURE - HIGH FLOW



Codice/Code

Z030202000

Packaging Box: 1 pz/pcs
27,5x18,5x51,5

PIASTRE INDIVIDUALI - Individual plates

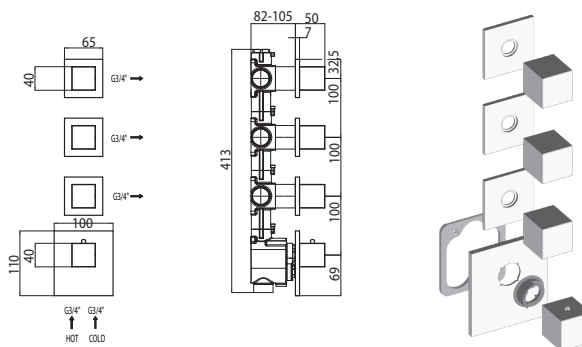

Piastre singole per installazione orizzontale o verticale

Exposed individual plates with vertical/horizontal installation

Aufputzteile mit Waagrecht- oder Senkrechteinbau Einzelplatten

Plaques individuelles pour installation horizontale ou verticale

Placas individuales para instalación horizontal o vertical

Установка вертикальная/горизонтальная для термостатического смесителя

Codice/Code Finitura/Finish

Z031205 030 cromo/chrome

Z033205 030 cromo/chrome

Z032205 030 cromo/chrome

Packaging Box: 1 pz/pcs
26x6x27

Z030270000 Miscelatori Termostatici Alta Portata - 4 USCITE / OUTLETS

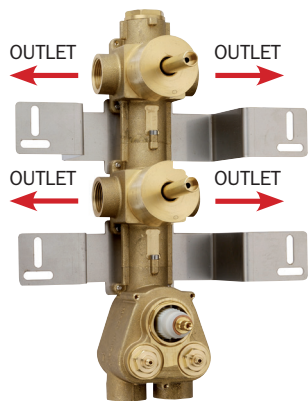

Parti incasso per miscelatore termostatico alta portata a 4 USCITE con 2 deviatori 2 vie e attacchi da 3/4". Installazione orizzontale o verticale

Concealed parts for high-flow 4 OUTLETS thermostatic mixer with 2 2-ways diverters and 3/4" connections. Horizontal or vertical installation

Unterputz-Einbaukörper für 4 AUSGÄNGE Hochdurchfluss Thermostat-Mischbatterie mit 2 2-Wege Umsteller und 3/4" Verbindungen. Waagrecht- oder Senkrechteinbau

Parties à encastrer pour mitigeur thermostatique haut débit 4 SORTIES avec 2 inverseurs 2 voies et connexions 3/4". Installation en vertical ou en horizontal.

Partes empotradas para mezclador termostático alta capacidad 4 SALIDAS con 2 desviadores 2 vías y conexiones 3/4". Instalación horizontal o vertical.

Детали, встроенного монтажа, для терmostатического смесителя, высокой пропускной способности, подключение на 3/4", 4 ВЫХОДА, (С ДЕВИАТОРОМ 2 НАПРАВЛЕНИЯ) установка вертикальная/горизонтальная

Codice/Code

Z030270000

Packaging Box: 1 pz/pcs
27,5x18,5x51,5

HP HIGH PRESSURE - HIGH FLOW



PIASTRA INTERA - Single back plate

**Z031204****Z033204****Z032204**

Piastra intera per installazione orizzontale o verticale.

Exposed single back plate vertical/horizontal installation

Aufputzteile mit Waagrecht- oder Senkrechteinbau Vollplatte

Plaque multi-éléments pour installation horizontale ou verticale

Placa entera para instalación horizontal o vertical

Установка вертикальная/горизонтальная для терmostатического смесителя

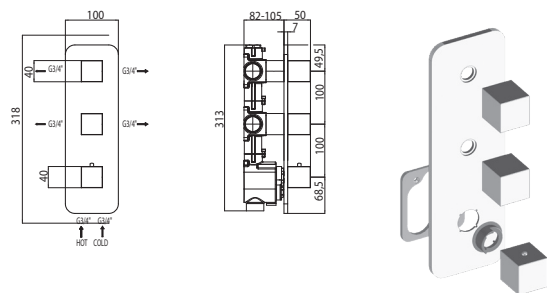

Codice/Code Finitura/Finish

Z031204 030 cromo/chrome**Z033204** 030 cromo/chrome**Z032204** 030 cromo/chrome

Packaging Box: 1 pz/pcs
21x7x49

PIASTRE INDIVIDUALI - Individual plates

**Z031203****Z033203****Z032203**

Piastre singole per installazione orizzontale o verticale

Exposed individual plates with vertical/horizontal installation

Aufputzteile mit Waagrecht- oder Senkrechteinbau Einzelplatten.

Plaques individuelles pour installation horizontale ou verticale

Placas individuales para instalación horizontal o vertical

Установка вертикальная/горизонтальная для терmostатического смесителя

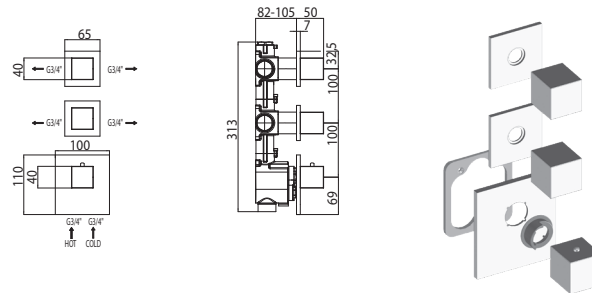

Codice/Code Finitura/Finish

Z031203 030 cromo/chrome**Z033203** 030 cromo/chrome**Z032203** 030 cromo/chrome

Packaging Box: 1 pz/pcs
26x6x27

Z030271000 Miscelatori Termostatici Alta Portata - 4 USCITE / OUTLETS

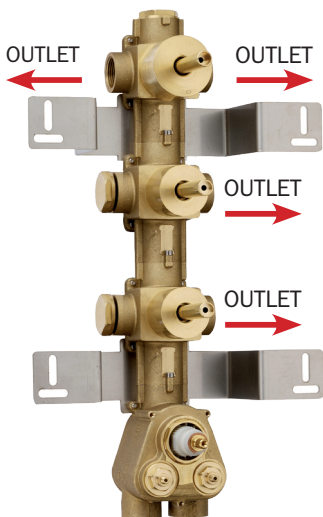

Parti incasso per miscelatore termostatico alta portata a 4 USCITE con 1 deviatore 2 vie, 2 valvole on-off e attacchi da 3/4". Installazione orizzontale o verticale

Concealed parts for high-flow 4 OUTLETS thermostatic mixer with 1 2-ways diverter, 2 stop valves and 3/4" connections. Horizontal or vertical installation

Unterputz-Einbaukörper für 4 AUSGÄNGE Hochdurchfluss Thermostat-Mischbatterie mit 1 2-Wege Umsteller, 2 Stoppventile und 3/4" Verbindungen. Waagrecht- oder Senkrechteinbau

Parties à encastrer pour mitigeur thermostatique haut débit 4 SORTIES avec 1 inverseur 2 voies, 2 robinets d'arrêt et connexions 3/4". Installation en vertical ou en horizontal.

Partes empotradas para mezclador termostático alta capacidad 4 SALIDAS con 1 desviador 2 vías, 2 llaves de paso y conexiones 3/4". Instalación horizontal o vertical.

Детали, встроенного монтажа, для термостатического смесителя, высокой пропускной способности, подключение на 3/4", 4 ВЫХОДА (ДЕВИАТОР НА 2 НАПРАВЛЕНИЯ и 2 запорных вентилей), установка вертикальная/горизонтальная

HP HIGH PRESSURE - HIGH FLOW



Codice/Code

Z030271000

Packaging Box: 1 pz/pcs
27,5x18,5x51,5

PIASTRE INDIVIDUALI - Individual plates



Z031205

Z033205

Z032205

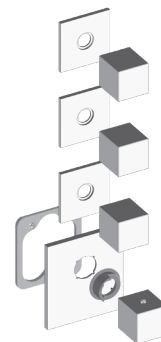
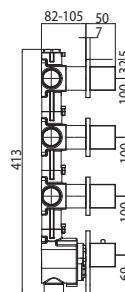
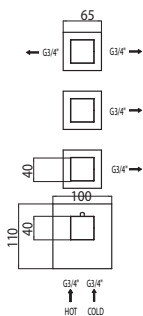

Piastre singole per installazione orizzontale o verticale
Exposed individual plates with vertical/horizontal installation
Aufputzteile mit Waagrecht- oder Senkrechteinbau Einzelplatten
Plaques individuelles pour installation horizontale ou verticale
Placas individuales para instalación horizontal o vertical
Установка вертикальная/горизонтальная для термостатического смесителя

Codice/Code Finitura/Finish

Z031205 030 cromo/chrome

Z033205 030 cromo/chrome

Z032205 030 cromo/chrome

Packaging Box: 1 pz/pcs
26x6x27

Z030210000 Miscelatori Termostatici Alta Portata - 5 USCITE / OUTLETS

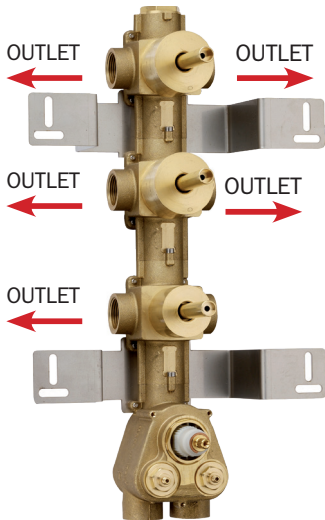

Parti incasso per miscelatore termostatico alta portata a 5 USCITE con 2 deviatori 2 vie, 1 valvola on-off e attacchi da 3/4". Installazione orizzontale o verticale

Concealed parts for high-flow 5 OUTLETS thermostatic mixer with 2 2-ways diverters, 1 stop valve and 3/4" connections. Horizontal or vertical installation

Unterputz-Einbaukörper für 5 AUSGÄNGE Hochdurchfluss Thermostat-Mischbatterie mit 2 2-Wege Umsteller, 1 Stoppventil und 3/4" Verbindungen. Waagrecht- oder Senkrechteinbau

Parties à encastrer pour mitigeur thermostatique haut débit 5 SORTIES avec 2 inverseurs 2 voies, 1 robinet d'arrêt et connexions 3/4". Installation en vertical ou en horizontal.

Partes empotradas para mezclador termostático alta capacidad 5 SALIDAS con 2 desviadores 2 vías, 1 llave de paso y conexiones 3/4". Instalación horizontal o vertical.

Codice/Code

Z030210000

Packaging Box: 1 pz/pcs
27,5x18,5x51,5

Детали, встроенного монтажа, для терmostатического смесителя, высокой пропускной способности, подключение на 3/4", 5 ВЫХОДОВ (ДЕВИАТОР НА 2 НАПРАВЛЕНИЯ и 1 запорный вентиль), установка вертикальная/ горизонтальная

HP HIGH PRESSURE - HIGH FLOW



PIASTRE INDIVIDUALI - Individual plates



Z031205

Z033205

Z032205

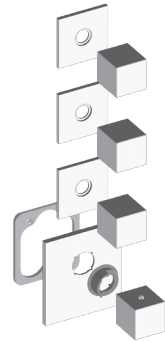
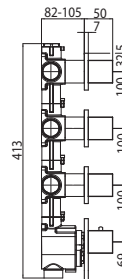
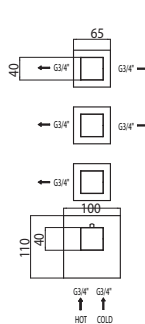

Piastre singole per installazione orizzontale o verticale

Exposed individual plates with vertical/horizontal installation

Aufputzteile mit Waagrecht- oder Senkrechteinbau Einzelplatten

Plaques individuelles pour installation horizontale ou verticale

Placas individuales para instalación horizontal o vertical

Установка вертикальная/горизонтальная для терmostатического смесителя

Codice/Code Finitura/Finish

Z031205 030 cromo/chrome

Z033205 030 cromo/chrome

Z032205 030 cromo/chrome

Packaging Box: 1 pz/pcs
26x6x27

Z030275000 Miscelatori Termostatici Alta Portata - 5 USCITE / OUTLETS

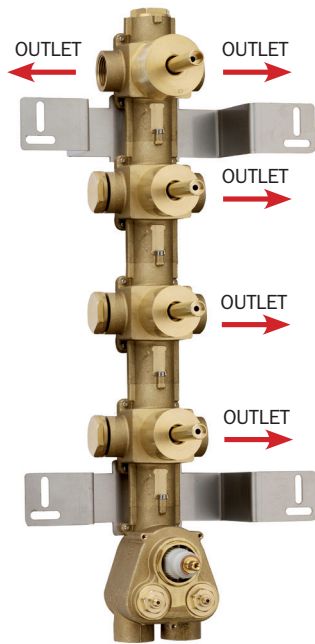

Parti incasso per miscelatore termostatico alta portata a 5 USCITE con 1 deviatore 2 vie, 3 valvole on-off e attacchi da 3/4". Installazione orizzontale o verticale

Concealed parts for high-flow 5 OUTLETS thermostatic mixer with 1 2-ways diverter, 3 stop valves and 3/4" connections. Horizontal or vertical installation

Unterputz-Einbaukörper für 5 AUSGÄNGE Hochdurchfluss Thermostat-Mischbatterie mit 1 2-Wege Umsteller, 3 Stoppventile und 3/4" Verbindungen. Waagrecht- oder Senkrechteinbau

Parties à encastrer pour mitigeur thermostatique haut débit 5 SORTIES avec 1 inverseur 2 voies, 3 robinets d'arrêt et connexions 3/4". Installation en vertical ou en horizontal.

Partes empotradas para mezclador termostático alta capacidad 5 SALIDAS con 1 desviador 2 vías, 3 llaves de paso y conexiones 3/4". Instalación horizontal o vertical.

Codice/Code

Z030275000

Packaging Box: 1 pz/pcs
35x24x81

Детали, встроенного монтажа, для термостатического смесителя, высокой пропускной способности, подключение на 3/4", 5 ВЫХОДОВ (ДЕВИАТОР НА 2 НАПРАВЛЕНИЯ и 3 запорных вентиля), установка вертикальная/горизонтальная

HP HIGH PRESSURE - HIGH FLOW



PIASTRE INDIVIDUALI - Individual plates

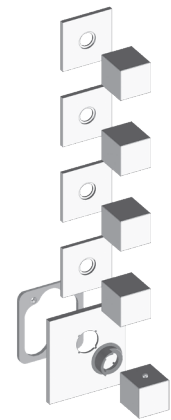
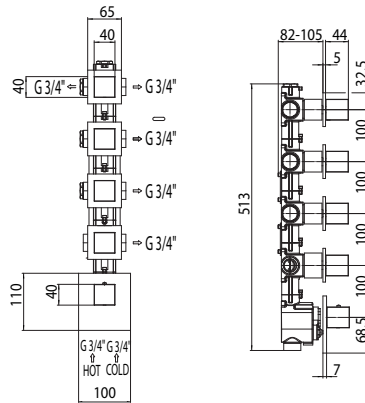

Piastre singole per installazione orizzontale o verticale
Exposed individual plates with vertical/horizontal installation
Aufputzteile mit Waagrecht- oder Senkrechteinbau Einzelplatten
Plaques individuelles pour installation horizontale ou verticale
Placas individuales para instalación horizontal o vertical
Установка вертикальная/горизонтальная для термостатического смесителя

Codice/Code Finitura/Finish

Z031208 030 cromo/chrome

Z033208 030 cromo/chrome

Z032208 030 cromo/chrome

Packaging Box: 1 pz/pcs
21x7x49

Z030273000 Miscelatori Termostatici Alta Portata - 6 USCITE / OUTLETS

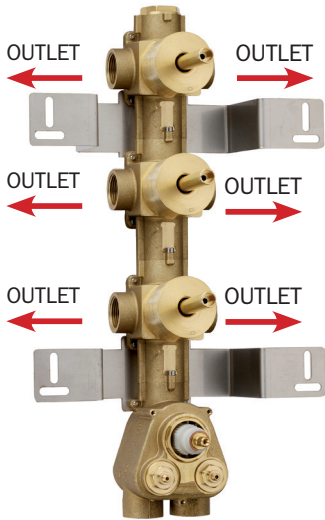

Parti incasso per miscelatore termostatico alta portata a 6 USCITE con 3 deviatori 2 vie e attacchi da ¾". Installazione orizzontale o verticale

Concealed parts for high-flow 6 OUTLETS thermostatic mixer with 3 2-ways diverters and ¾" connections. Horizontal or vertical installation

Unterputz-Einbaukörper für 6 AUSGÄNGE Hochdurchfluss Thermostat-Mischbatterie mit 3 2-Wege Umsteller und ¾" Verbindungen. Waagrecht- oder Senkrechteinbau

Parties à encastrer pour mitigeur thermostatique haut débit 6 SORTIES avec 3 inverseurs 2 voies et connexions ¾". Installation en vertical ou en horizontal.

Partes empotradas para mezclador termostático alta capacidad 6 SALIDAS con 3 desviadores 2 vías y conexiones ¾". Instalación horizontal o vertical.

Детали, встроенного монтажа, для термостатического смесителя, высокой пропускной способности, подключение на ¾", 6 ВЫХОДОВ, (С ДЕВИАТОРОМ 2 НАПРАВЛЕНИЯ) установка вертикальная/горизонтальная

HP HIGH PRESSURE - HIGH FLOW

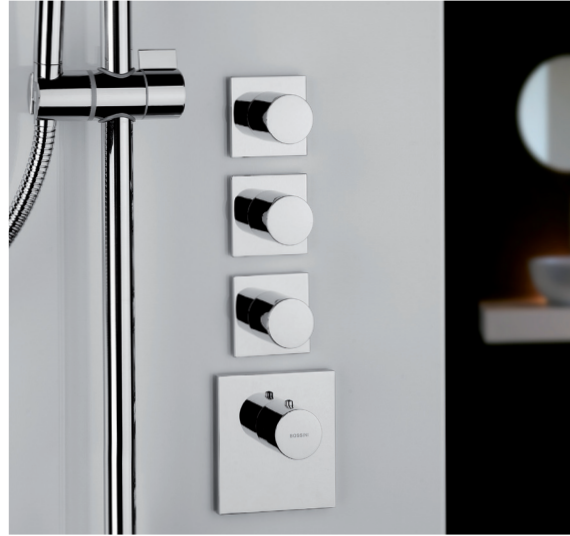

Codice/Code

Z030273000

Packaging Box: 1 pz/pcs
27,5x18,5x51,5

PIASTRE INDIVIDUALI - Individual plates



Z031205



Z033205



Z032205

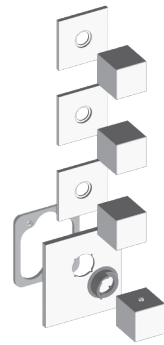
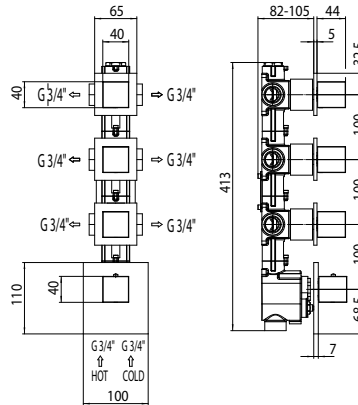

Piastre singole per installazione orizzontale o verticale

Exposed individual plates with vertical/horizontal installation

Aufputzteile mit Waagrecht- oder Senkrechteinbau Einzelplatten

Plaques individuelles pour installation horizontale ou verticale

Placas individuales para instalación horizontal o vertical

Установка вертикальная/горизонтальная для термостатического смесителя

Codice/Code Finitura/Finish

Z031205 030 cromo/chrome

Z033205 030 cromo/chrome

Z032205 030 cromo/chrome

Packaging Box: 1 pz/pcs
26x6x27

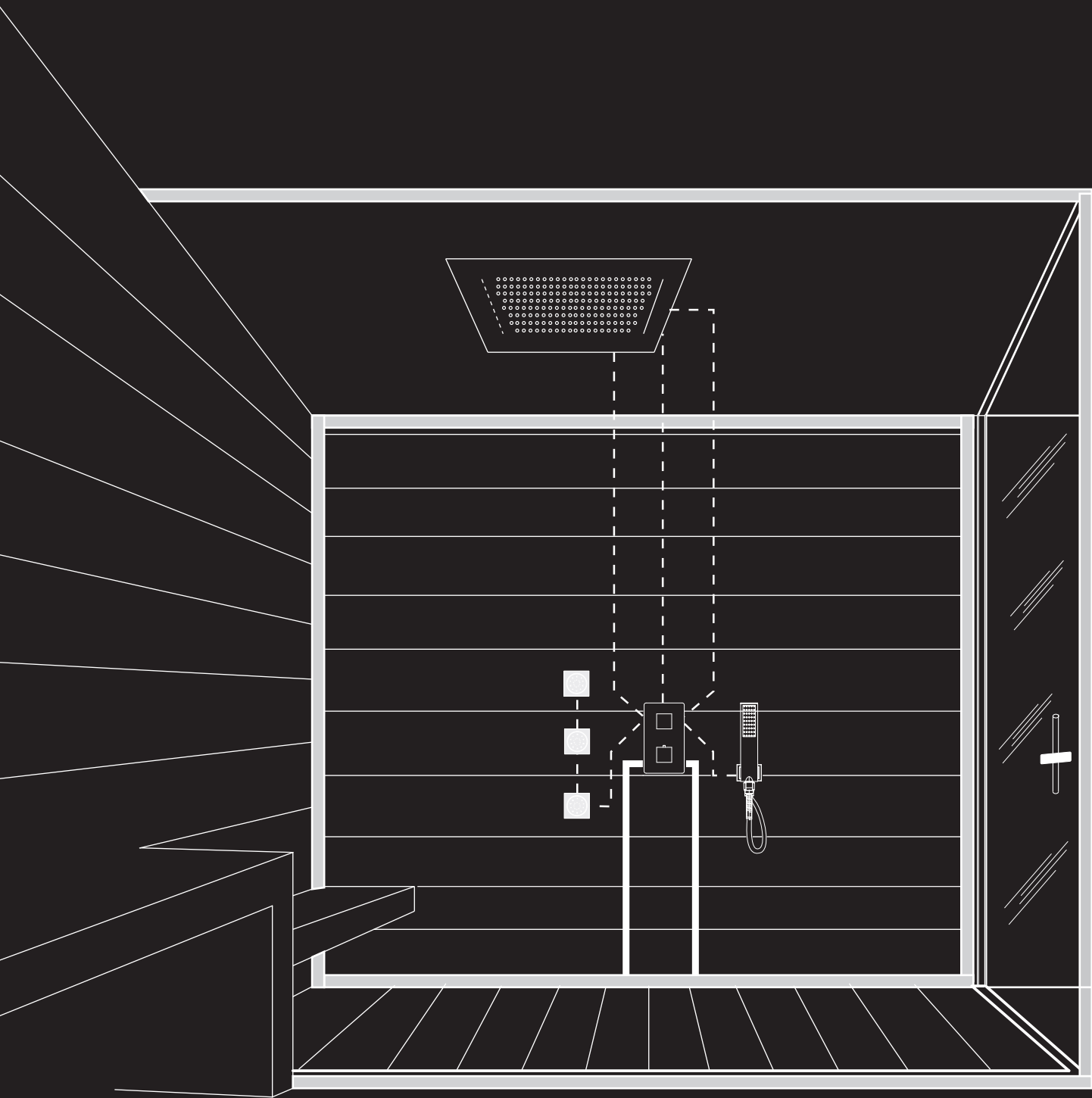



Informazioni tecniche

Technical information

Shower Installation Solutions Universal Mixers

Vi proponiamo differenti soluzioni d'installazione da 2 a 5 vie, per facilitare i progettisti nello studio del vostro ambiente doccia.

We offer various installation solutions, from 2 to 5 ways, to help designers create your shower environment.

Wir schlagen Ihnen unterschiedliche Installationslösungen mit 2- bis 5-Wege-Anschluss vor, um Ihnen die Planung Ihres individuellen Dusch-Ambientes zu erleichtern.

Nous vous proposons différentes solutions d'installation de 2 à 5 voies afin d'aider les projeteurs dans l'étude de votre environnement douche.

Les ofrecemos diferentes soluciones de instalación de 2 a 5 vías para ayudar a los diseñadores en el proyecto de vuestro ambiente de ducha.

Предлагаем Вам разные варианты установки от 2 до 5 направлений, для упрощения проектирования помещения Вашей ванной комнаты.

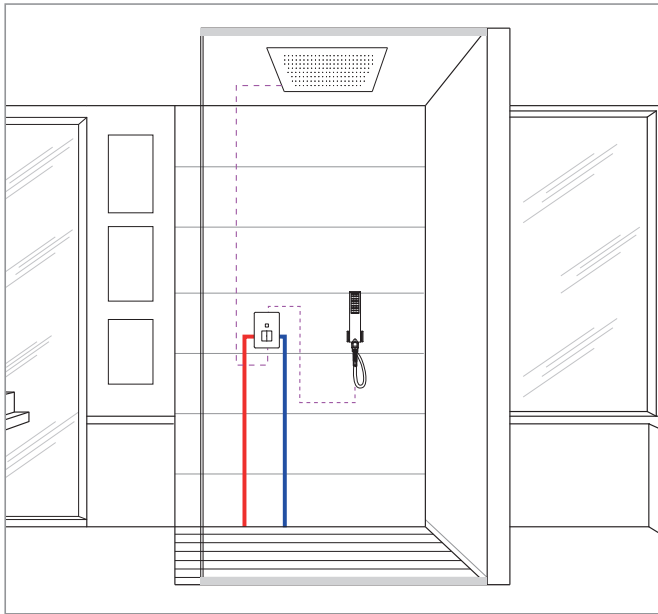

2
WAYS
2 USCITE
2 OUTLETS

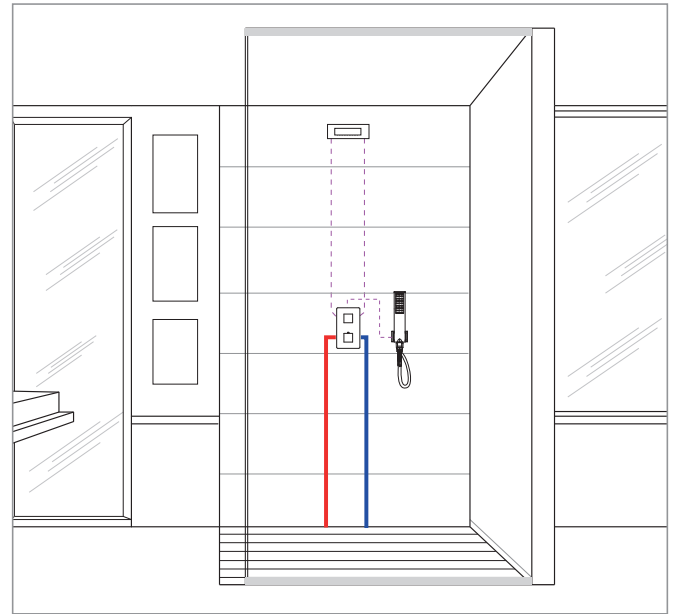

3
WAYS
3 USCITE
3 OUTLETS

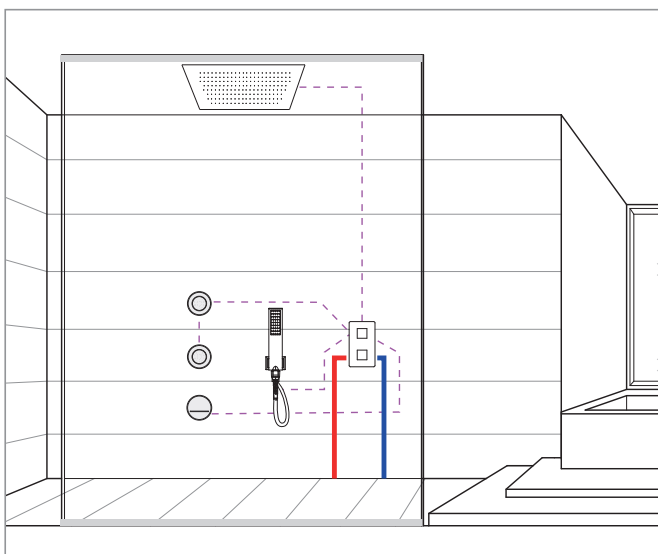

4
WAYS
4 USCITE
4 OUTLETS

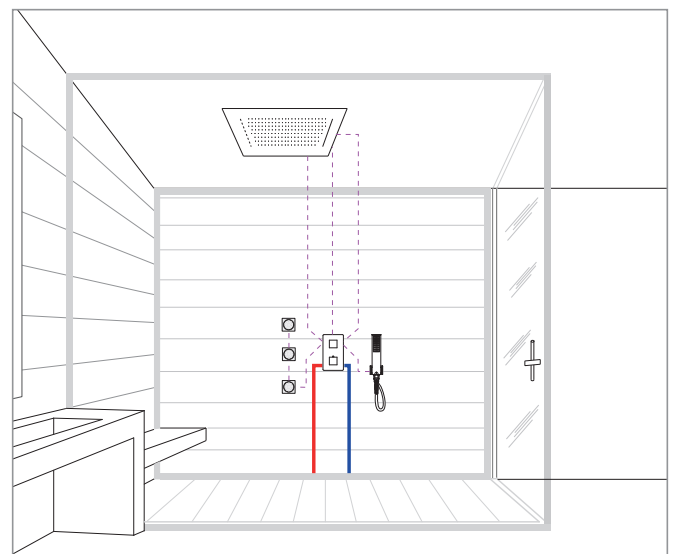

5
WAYS
5 USCITE
5 OUTLETS



Universal Thermostatic MIXERS

Miscelatore termostatico con deviatore a 1/2/3/4/5 vie da 1/2". La manopola inferiore regola la temperatura dell'acqua ed è dotata del blocco di sicurezza a 38°C.

Thermostatic mixer with 1/2/3/4/5 ways diverter 1/2". The water temperature is selected through the lower knob which is also provided with anti-scald button locking the temperature at 38°C.

Mitigeur thermostatique avec inverseur 1/2/3/4/5 voies 1/2". La poignée inférieure règle la température de l'eau et est munie d'un bouton de sécurité qui bloque la température à 38°C.

Mezclador termostático de empotrar con desviador 1/2/3/4/5 vías 1/2". La maneta inferior regula la temperatura del agua y incluye un pulsador de bloqueo de seguridad a los 38°C.

Die UP-Thermostat Brausebatterie mit 1/2/3/4/5 Wegeumstellung 1/2". Der untere Griff – der die Wassertemperatur einstellt- ist mit Sicherheitsverriegelungssystem bis zu 38°C versehen.

Смеситель термостатический с переключением на 1/2/3/4/5 1/2". Нижняя ручка позволяет регулировать температуру подачи воды и оснащена предохранительным клапаном на 38°C.

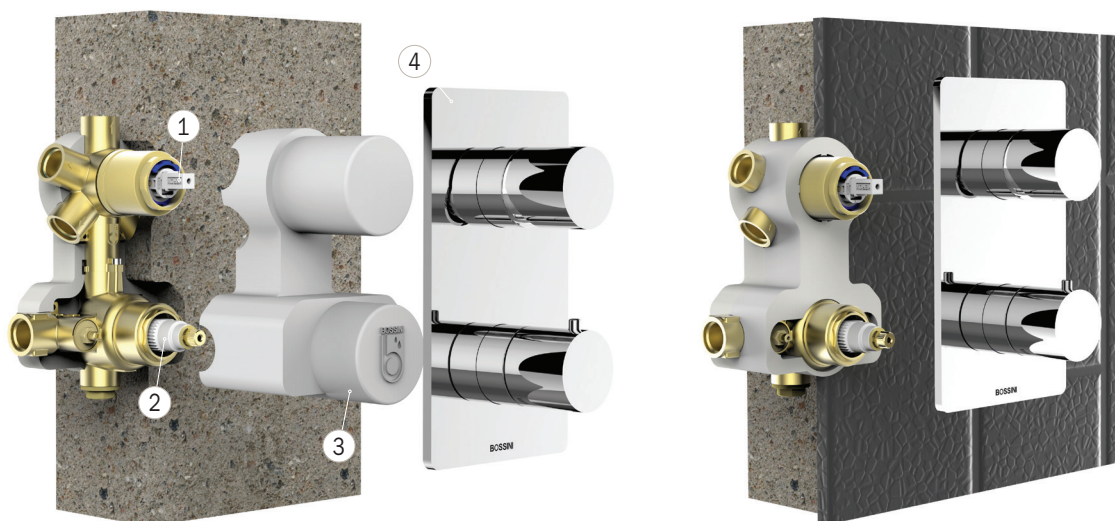

①



Cartuccia deviatore e regolazione del flusso con dischi ceramici

Ceramic discs cartridge for deviation and flow regulation

②



Cartuccia termostatica
Thermostatic cartridge

③

Protezione in polistirolo
Polystyrene protection

④

Parti esterne
Exposed parts



Regolazione della temperatura
Temperature regulation
Temperaturregulierung
Régulation de la température
Regulación de la temperatura
Регулировка температуры

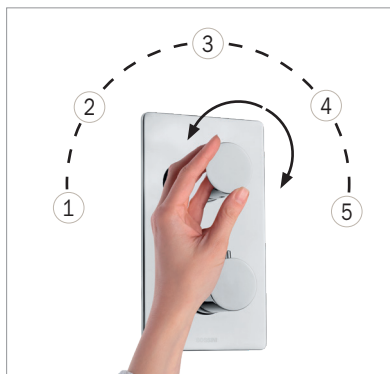

Ruotando devia da 1 a 5 vie
By turning the handle diverts (from 1 to 5 ways)
Durch drehen stellt der Griff um (von 1 bis 5 Wege)
En tournant la poignée dévie (de 1 à 5 voies)
Girando el mango desvía (de 1 a 5 vías)
Поворачивая, переключает на выходы от 1 до 5



On-Off e regolazione del flusso
On-Off, flow and temperature regulation
Ouvre-Ferme, régulation débit et température
Abre-Cierre, regulación caudal y temperatura
Öffnet-schließt, Durchfluss und Temperatur verstellt
Открывает/закрывает/регулирует поток

Installation solutions

1-2-3-4-5 WAYS

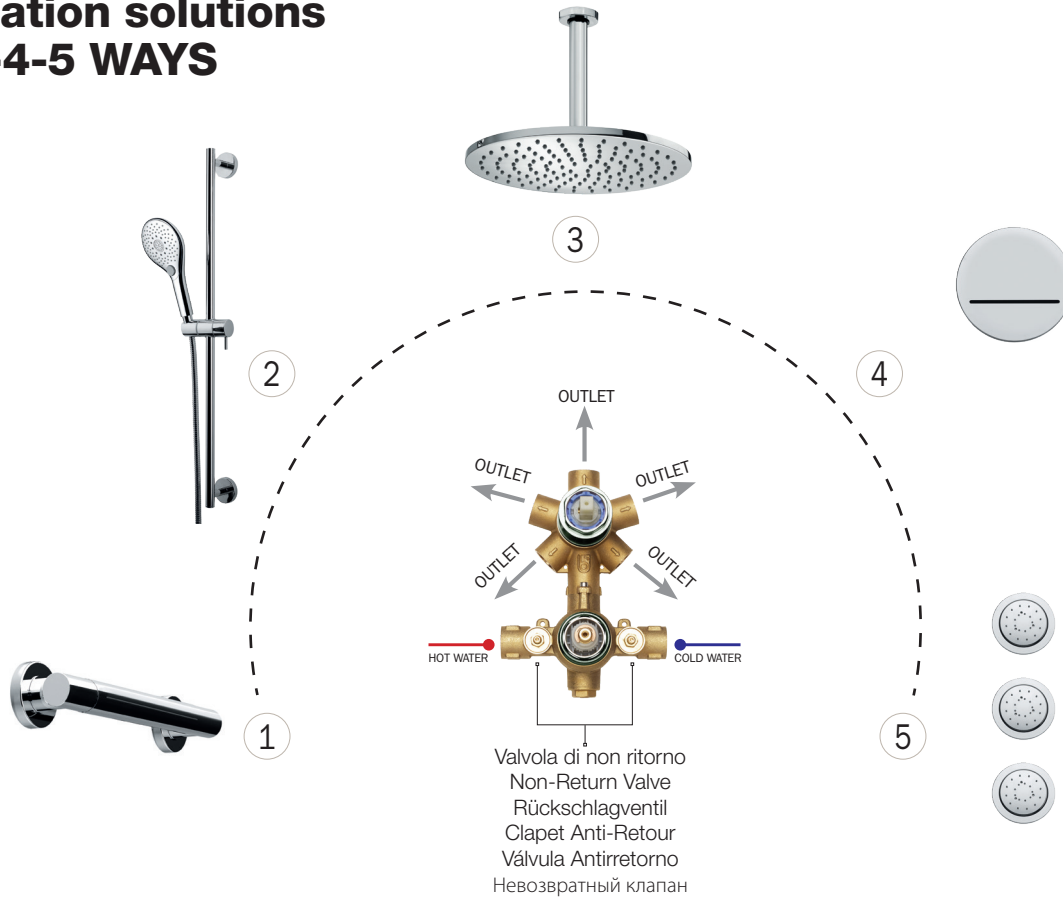

Il corpo del miscelatore è dotato di meccanismo di chiusura, posizionato in corrispondenza delle valvole di non ritorno, che consente di interrompere l'erogazione dell'acqua per la manutenzione della cartuccia termostatica e/o del deviatore, senza ricorrere alla chiusura centralizzata dell'impianto.

The mixer body incorporates an on-off device, installed by the non-return valves, which allows to easily turn off the water whenever maintenance at the thermostatic or diverter cartridges is required, without need of closing the main supply.

Le corps du mitigeur est équipé d'un système de fermeture, positionné au même endroit que les clapets anti-retour, qui permet d'interrompre l'arrivée d'eau pour la manutention des cartouches thermostatiques ou des inverseurs.

El cuerpo empotrado incorpora un dispositivo de cierre, posicionado sobre las válvulas antirretorno, que permite la interrupción de alimentación de agua para el fácil mantenimiento / sustitución del cartucho termostático o desviador.

Der Thermostatkörper integriert ein Absperrsystem bei der Rückflussverhinderung, um die Kartuschenpflege und Ersatz einfach zu machen.

Корпус смесителя оснащен механизмом закрытия, расположенным в соответствии с невозвратными клапанами, который позволяет перекрывать подачу воды при необходимости ухода или обслуживания за термостатическим картриджем или девиатором, не прибегая к централизованному отключению.

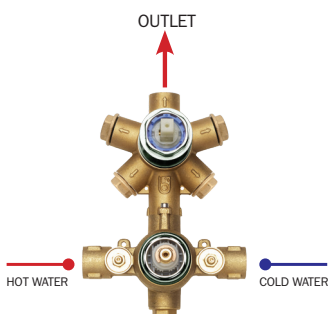

1 WAY

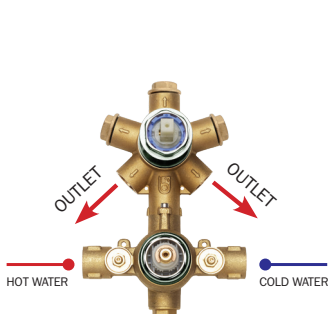
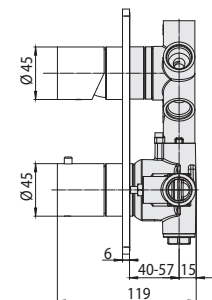
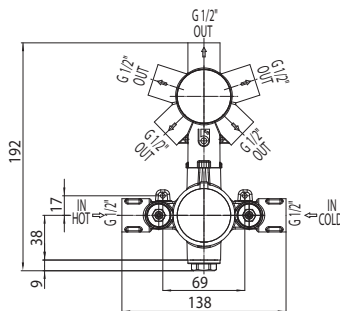
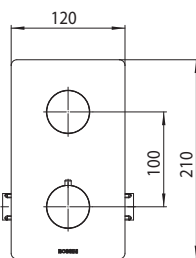

2 WAYS

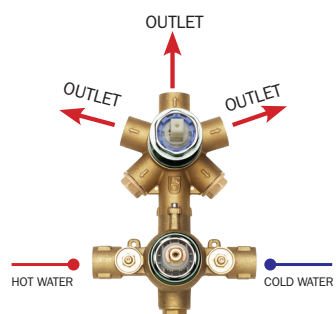

3 WAYS

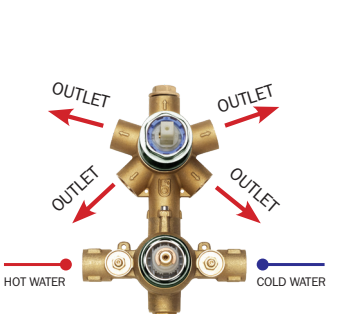

4 WAYS

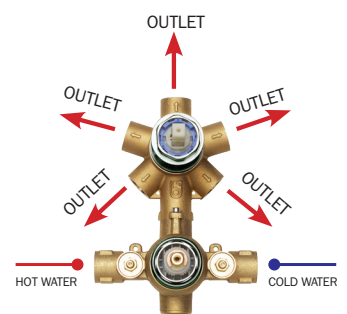

5 WAYS

Universal Single Lever MIXERS

Miscelatore monocomando con deviatore a 1/2/3/4/5 vie 1/2".

Single lever mixer with 1/2/3/4/5 ways diverter 1/2".

Mitigeur monocommande avec inverseur 1/2/3/4/5 voies 1/2".

Mezclador monomando de empotrar con desviador 1/2/3/4/5 vias 1/2".

Die Einhebel Brausebatterie mit 1/2/3/4/5 Wegeumstellung 1/2".

Предлагаем Вам разные варианты установки от 1/2/3/4/5 1/2".



- ①  Cartuccia deviatore
Cartridge for deviation
- ②  Cartuccia di miscelazione
e regolazione del flusso
Mixing and flow regulation
cartridge
- ③  Protezione in polistirolo
Polystyrene protection
- ④  Parti esterne
Exposed parts



Regolazione della temperatura
Temperature regulation
Temperaturregulierung
Régulation de la température
Regulación de la temperatura
Регулировка температуры

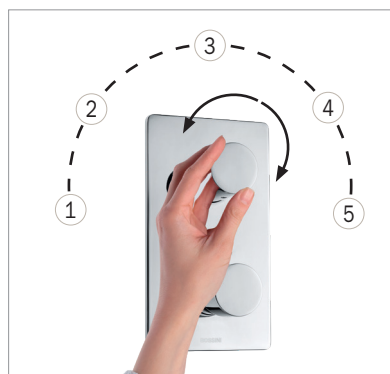

Ruotando devia da 1 a 5 vie
By turning the handle diverts (from 1 to 5 ways)
Durch drehen stellt der Griff um (von 1 bis 5 Wege)
En tournant la poignée dévie (de 1 à 5 voies)
Girando el mango desvía (de 1 a 5 vías)
Поворачивая, переключает на выходы от 1 до 5



On-Off e regolazione del flusso
On-Off, flow and temperature regulation
Ouvre-Ferme, régulation débit et température
Abre-Cierre, regulación caudal y temperatura
Öffnet-schließt, Durchfluss und Temperatur verstell
Открывает/закрывает/регулирует поток

Installation solutions

1-2-3-4-5 WAYS

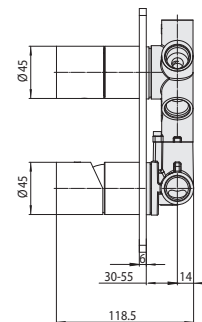
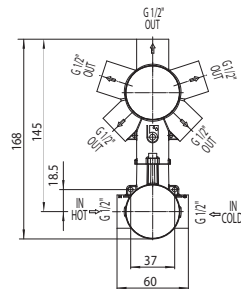
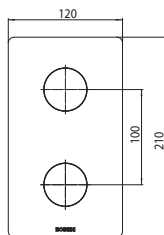
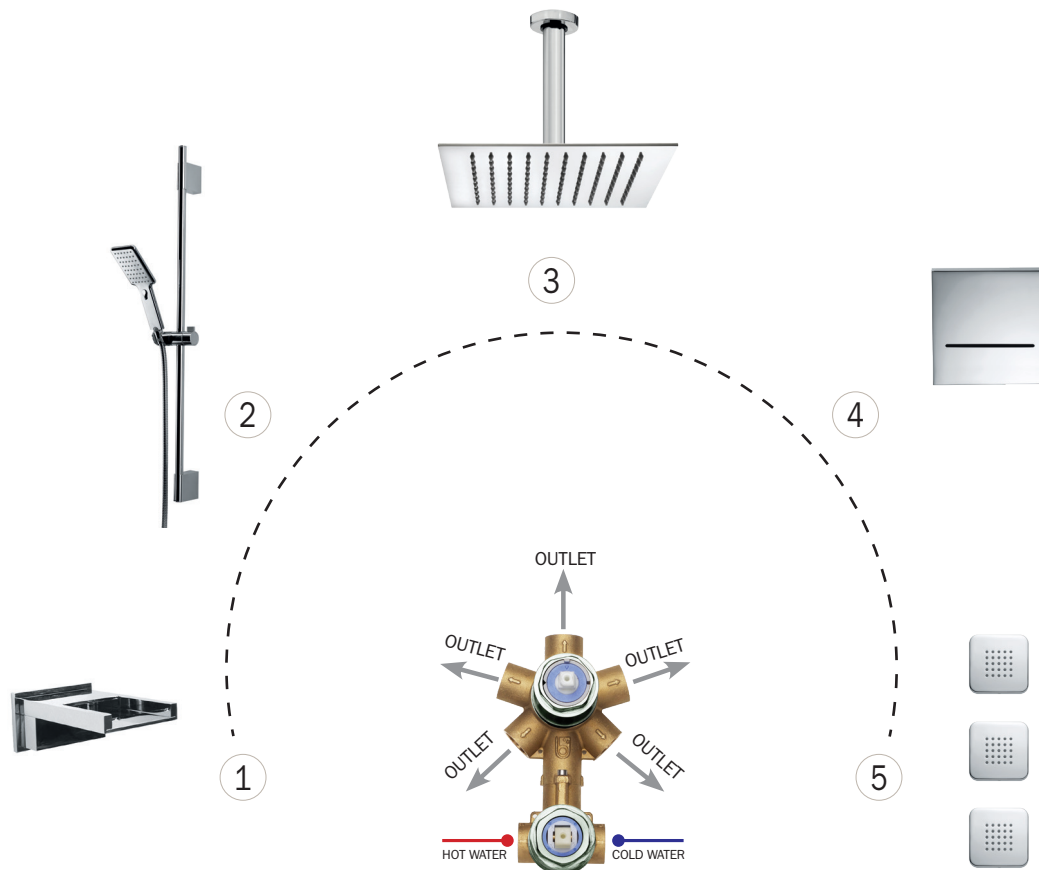

Mixers installation ways

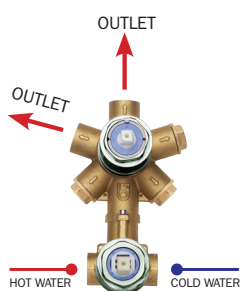

2 WAYS

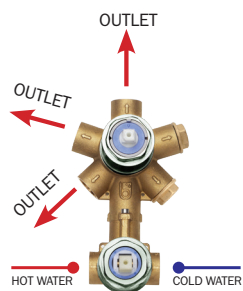

3 WAYS

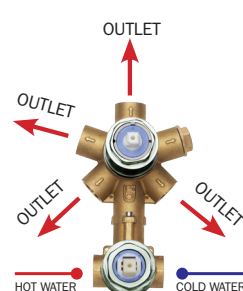

4 WAYS

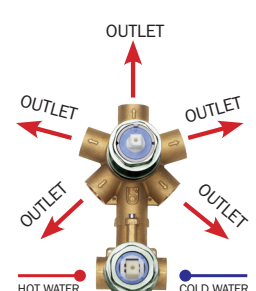

5 WAYS

Portate d'acqua

Flow rates - Durchflussmenge - Débit d'eau - Caudales - Пропускная способность

Z00007

MISCELATORE MONOCOMANDO 1 USCITA - 1 outlet single lever mixer - 1 Ausgang Einhebel Brausebatterie
Mitigeur monocommande 1 sortie - Mezclador monomando 1 salida - 1 однорычажный смеситель

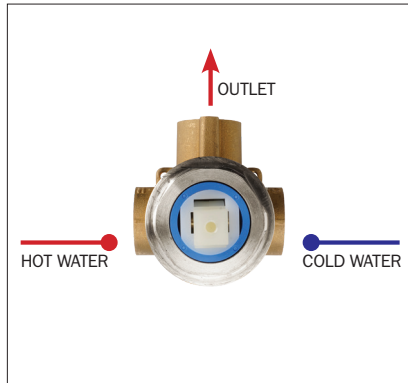

TEMPERATURA ACQUA FREDDA Cold water temperature Kaltwassertemperatur Température eau froide Temperatura agua fría Температура холодной воды	<20°C
TEMPERATURA ACQUA CALDA Hot water temperature Warmwassertemperatur Température eau chaude Temperatura agua caliente Температура горячей воды	60°C
COLLEGAMENTO Connection Anschluss Raccordement Conexión Соединение	DIRETTO 1/2" direct 1/2" direkt 1/2" direct 1/2" directo 1/2" Прямое 1/2"

	Uscita-Outlet
0	0
0,5	14,0
1	19,2
1,5	23,5
2	27,1
2,5	30,1
3	32,9
3,5	35,4
4	37,7
4,5	40,2
5	42,3
Bar	L/min

Z00005

MISCELATORE MONOCOMANDO 2 USCITE - 2 outlets single lever mixer - 2 Ausgänge Einhebel Brausebatterie
Mitigeur monocommande 2 sorties - Mezclador monomando 2 salidas - 2 выхода однорычажный смеситель

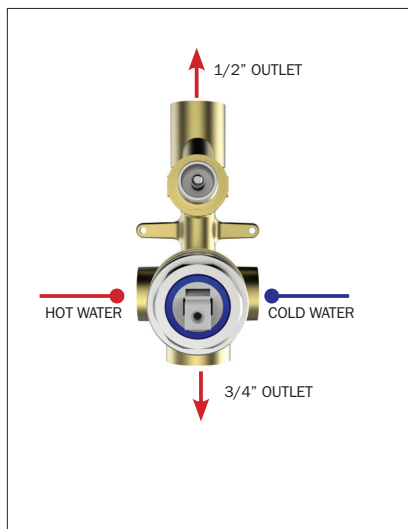

TEMPERATURA ACQUA FREDDA Cold water temperature Kaltwassertemperatur Température eau froide Temperatura agua fría Температура холодной воды	<20°C
TEMPERATURA ACQUA CALDA Hot water temperature Warmwassertemperatur Température eau chaude Temperatura agua caliente Температура горячей воды	60°C
COLLEGAMENTO Connection Anschluss Raccordement Conexión Соединение	DIRETTO 3/4" direct 3/4" direkt 3/4" direct 3/4" directo 3/4" Прямое 3/4"
COLLEGAMENTO Connection Anschluss Raccordement Conexión Соединение	DIRETTO 1/2" direct 1/2" direkt 1/2" direct 1/2" directo 1/2" Прямое 1/2"

	Uscita 3/4"	Uscita 1/2"
0	0,0	0,0
0,5	11,2	7,8
1	15,6	10,9
1,5	19,2	13,2
2	22,1	15,1
2,5	24,7	16,9
3	27,2	18,5
3,5	29,3	19,9
4	31,2	21,3
4,5	33,1	22,6
5	35,0	23,7
Bar	L/min	

Z00130

MISCELATORE MONOCOMANDO 1-2-3-4-5 USCITE - 1-2-3-4-5 outlets single lever mixer - 1-2-3-4-5 Ausgänge
Einhebel Brausebatterie - Mitigeur monocommande 1-2-3-4-5 sorties - Mezclador monomando 1-2-3-4-5 salidas
1-2-3-4-5 розетки однорычажный смеситель

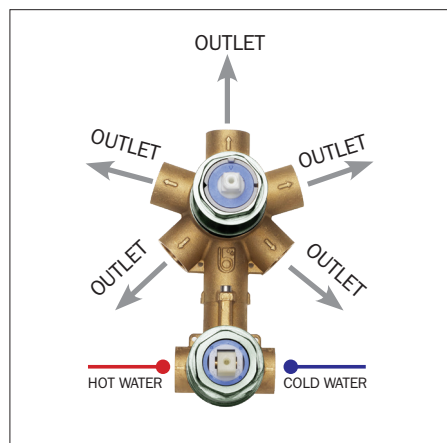

TEMPERATURA ACQUA FREDDA Cold water temperature Kaltwassertemperatur Température eau froide Temperatura agua fría Температура холодной воды	<20°C
TEMPERATURA ACQUA CALDA Hot water temperature Warmwassertemperatur Température eau chaude Temperatura agua caliente Температура горячей воды	60°C
COLLEGAMENTO Connection Anschluss Raccordement Conexión Соединение	DIRETTO 1/2" direct 1/2" direkt 1/2" direct 1/2" directo 1/2" Прямое 1/2"

	Uscita-Outlet
0	0,0
0,5	7,5
1	12,6
1,5	16,6
2	19,2
2,5	21,8
3	24,1
3,5	26,2
4	28,4
4,5	30,0
5	31,8
Bar	L/min

Z00125

MISCELATORE TERMOSTATICO 1-2-3-4-5 USCITE - 1-2-3-4-5 outlets thermostatic mixer 1-2-3-4-5 Ausgänge
Thermostat Brausebatterie - Mitigeur thermostatique 1-2-3-4-5 sorties - Mezclador termostático 1-2-3-4-5 salidas
Смеситель термостатический 1-2-3-4-5 выход

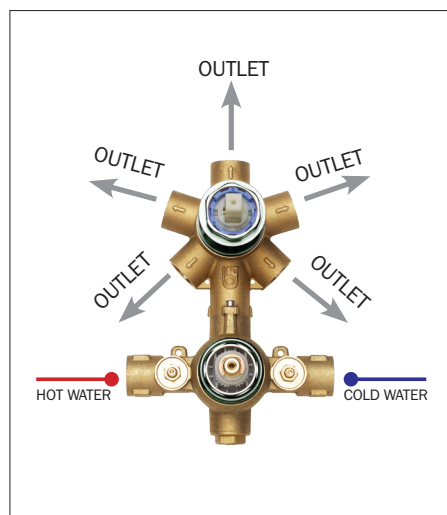

TEMPERATURA ACQUA MISCELATA Mixed water temperature Temperatur des gemischten Wassers Température eau mitigée Temperatura agua mezclada Температура смешанной воды	38°C
TEMPERATURA ACQUA FREDDA Cold water temperature Kaltwassertemperatur Température eau froide Temperatura agua fría Температура холодной воды	<20°C
TEMPERATURA ACQUA CALDA Hot water temperature Warmwassertemperatur Température eau chaude Temperatura agua caliente Температура горячей воды	60°C
COLLEGAMENTO Connection Anschluss Raccordement Conexión Соединение	DIRETTO 1/2" direct 1/2" direkt 1/2" direct 1/2" directo 1/2" Прямое 1/2"

	Uscita-Outlet
0	0,0
0,5	9,9
1	14,2
1,5	17,4
2	20,1
2,5	22,1
3	24,4
3,5	26,2
4	27,9
4,5	29,7
5	31,3
Bar	L/min

Shower Installation Solutions High Flow Mixers

Vi proponiamo differenti soluzioni d'installazione da 2 a 6 vie, per facilitare i progettisti nello studio del vostro ambiente doccia.

We offer various installation solutions from 2 to 6 ways, for helping designers to create your shower space.

Wir schlagen Ihnen unterschiedliche Installationslösungen von 2- bis 6-Wege Anschlüsse vor, um Ihnen die Planung Ihres individuellen Dusch Bereich zu erleichtern.

Nous vous proposons différentes solutions d'installation de 2 à 6 voies afin d'aider les projeteurs dans l'étude de votre espace douche.

Les ofrecemos diferentes soluciones de instalación de 2 a 6 vías para ayudar a los diseñadores en el proyecto de vuestro ambiente de ducha.

Предлагаем Вам разные варианты установки от 2 до 6 направлений, для упрощения проектирования помещения Вашей ванной комнаты.

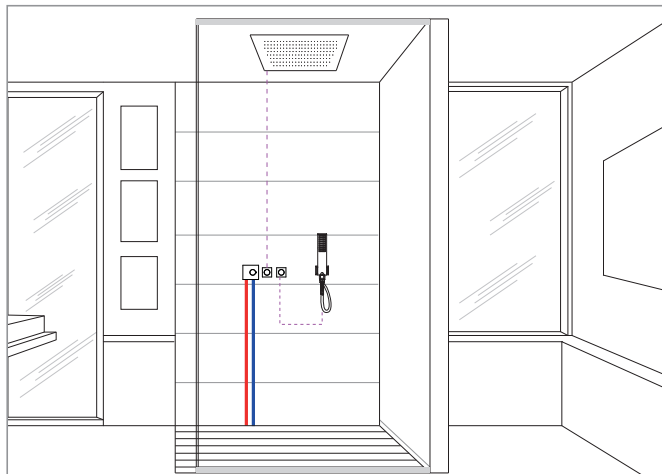

2
WAYS
2 USCITE: 2 vie singole
2 OUTLETS: 2 single ways

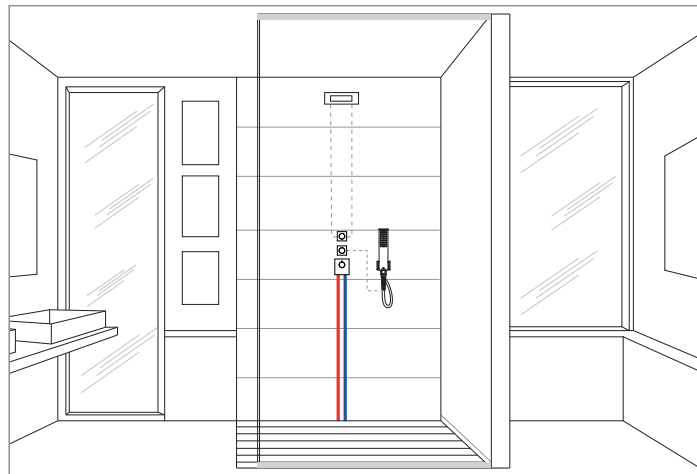

3
WAYS
3 USCITE: 1 deviatore con 2 vie + 1 via singola
3 OUTLETS: 2-ways diverter + 1 single way

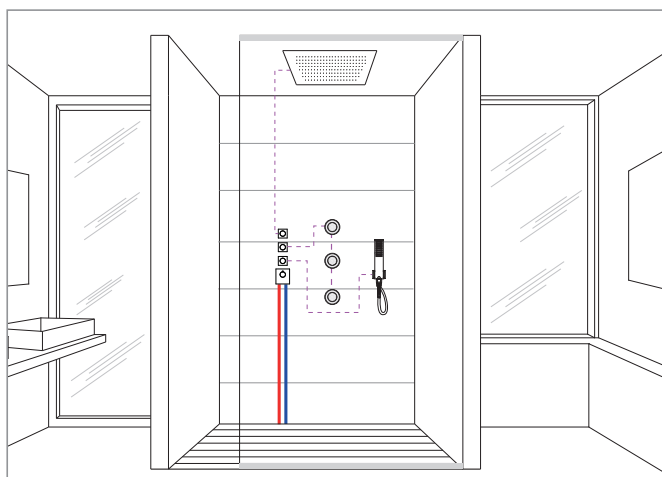

3
WAYS
3 USCITE: 3 vie singole
3 OUTLETS: 3 single ways

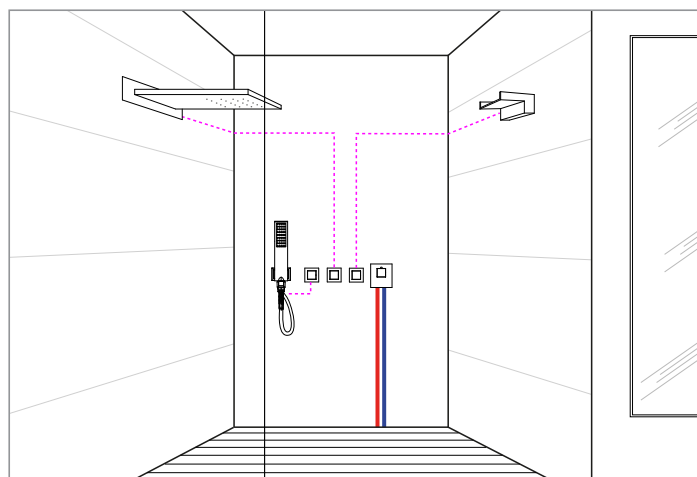

3
WAYS
3 USCITE: 3 vie singole
3 OUTLETS: 3 single ways

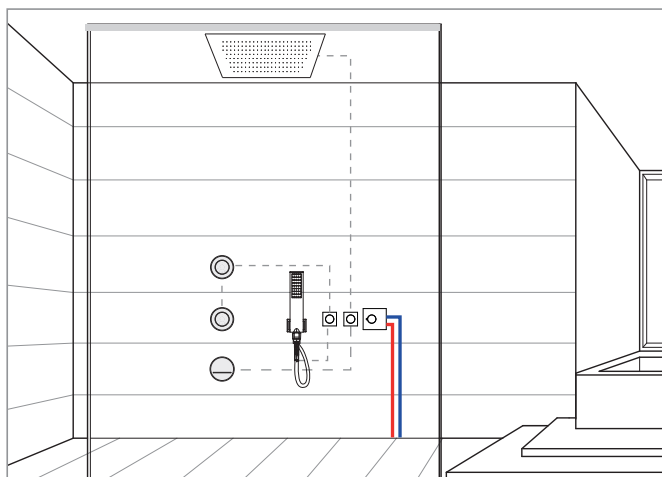

4
WAYS
4 USCITE: 2 deviatori con 4 vie
4 OUTLETS: 4 ways by 2-ways diverter

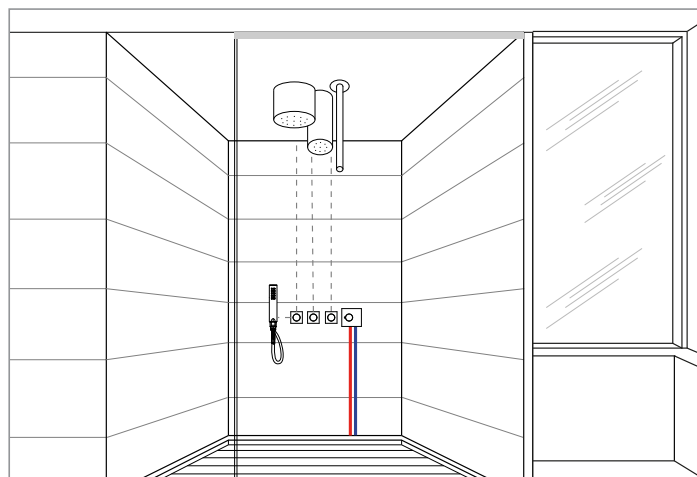

4
WAYS
4 USCITE: 1 deviatore con 2 vie + 2 vie singole
4 OUTLETS: 2-ways diverter + 2 single ways

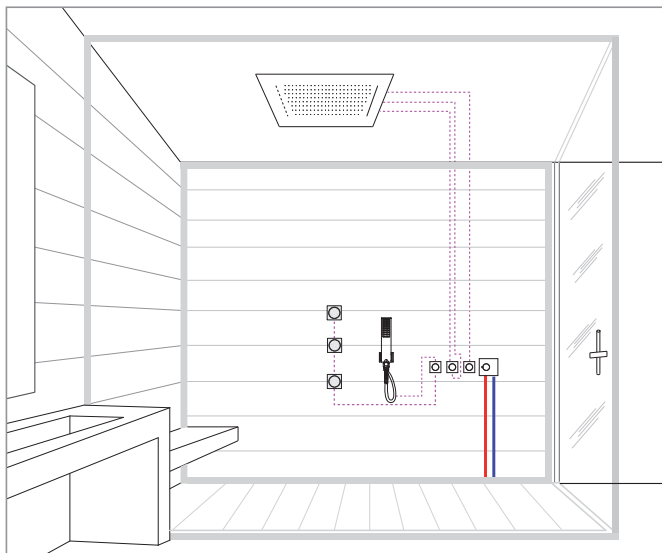

5 5 USCITE: 2 deviatori con 2 vie + 1 via singola
 WAYS 5 OUTLETS: Nr. 2 2-ways diverters + 1 single way

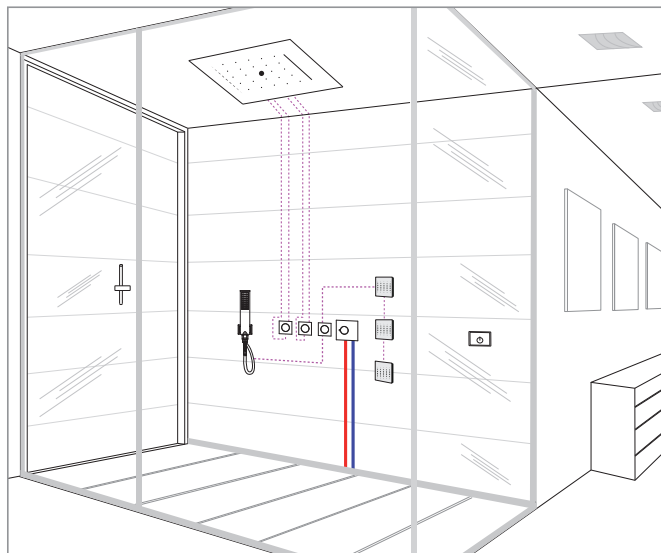

6 6 USCITE: 3 deviatori con 6 vie
 WAYS 6 OUTLETS: Nr. 3 2-ways diverters



Portate d'acqua HIGH FLOW MIXERS

Flow rates - Durchflussmenge - Débit d'eau - Caudales - Пропускная способность

Z030204 000



MISCELATORE TERMOSTATICO 1 USCITA - 1 outlet thermostatic mixer - 1 Ausgang Thermostat Brausebatterie
Mitigeur thermostatique 1 voie - Mezclador termostático 1 vía - Смеситель термостатический 1 выход

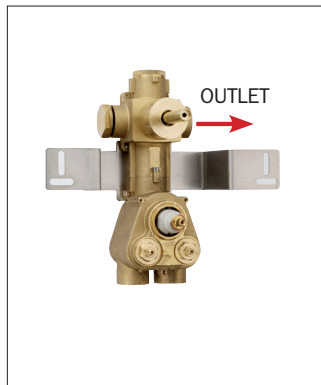

TEMPERATURA ACQUA MISCELATA - Mixed water temperature - Temperatur des gemischten Wassers - Température eau mitigée - Temperatura agua mezclada - Температура смешанной воды	38°C
TEMPERATURA ACQUA FREDDA - Cold water temperature - Kaltwassertemperatur - Température eau froide - Temperatura agua fría - Температура холодной воды	<20°C
TEMPERATURA ACQUA CALDA - Hot water temperature - Warmwassertemperatur - Température eau chaude - Temperatura agua caliente - Температура горячей воды	55-65°C
COLLEGAMENTO Connection Anschluss Raccordement Conexión Соединение	DIRETTO 3/4" direct 3/4" direkt 3/4" direct 3/4" directo 3/4" Прямое 3/4"

	1 RUB
0	0,0
0,5	17,4
1	25,0
1,5	30,9
2	35,4
2,5	39,5
3	43,3
3,5	46,6
4	50,1
4,5	53,3
5	56,3
Bar	L/min

Z030205 000



MISCELATORE TERMOSTATICO 2 USCITE - 2 outlets thermostatic mixer - 2 Ausgänge Thermostat Brausebatterie
Mitigeur thermostatique 2 voies - Mezclador termostático 2 vías - Смеситель термостатический 2 выход

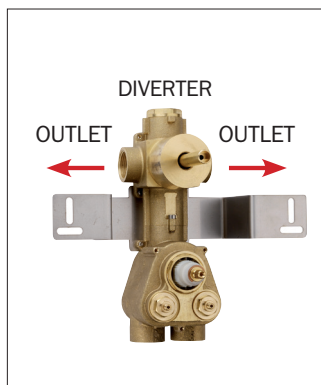

TEMPERATURA ACQUA MISCELATA - Mixed water temperature - Temperatur des gemischten Wassers - Température eau mitigée - Temperatura agua mezclada - Температура смешанной воды	38°C
TEMPERATURA ACQUA FREDDA - Cold water temperature - Kaltwassertemperatur - Température eau froide - Temperatura agua fría - Температура холодной воды	<20°C
TEMPERATURA ACQUA CALDA - Hot water temperature - Warmwassertemperatur - Température eau chaude - Temperatura agua caliente - Температура горячей воды	55-65°C
COLLEGAMENTO Connection Anschluss Raccordement Conexión Соединение	DIRETTO 3/4" direct 3/4" direkt 3/4" direct 3/4" directo 3/4" Прямое 3/4"

	1 DEV
0	0,0
0,5	15,8
1	21,7
1,5	26,4
2	30,5
2,5	34,0
3	37,5
3,5	40,8
4	43,7
4,5	46,6
5	49,4
Bar	L/min

Z030201 000



MISCELATORE TERMOSTATICO 2 USCITE - 2 outlets thermostatic mixer 2 Ausgänge Thermostat Brausebatterie
Mitigeur thermostatique 2 voies - Mezclador termostático 2 vías - Смеситель термостатический 2 выход

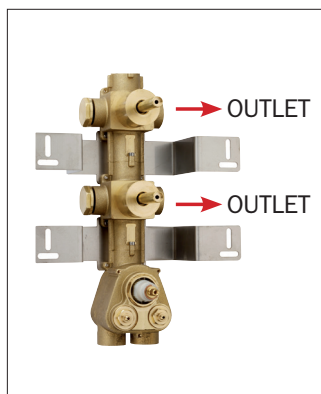

TEMPERATURA ACQUA MISCELATA - Mixed water temperature - Temperatur des gemischten Wassers - Température eau mitigée - Temperatura agua mezclada - Температура смешанной воды	38°C
TEMPERATURA ACQUA FREDDA - Cold water temperature - Kaltwassertemperatur - Température eau froide - Temperatura agua fría - Температура холодной воды	<20°C
TEMPERATURA ACQUA CALDA - Hot water temperature - Warmwassertemperatur - Température eau chaude - Temperatura agua caliente - Температура горячей воды	55-65°C
COLLEGAMENTO Connection Anschluss Raccordement Conexión Соединение	DIRETTO 3/4" direct 3/4" direkt 3/4" direct 3/4" directo 3/4" Прямое 3/4"

	1 USCITA	2 USCITE
0	0,0	0,0
0,5	17,4	19,2
1	25,0	27,9
1,5	30,9	34,3
2	35,4	39,9
2,5	39,5	44,9
3	43,3	49,1
3,5	46,6	53,4
4	50,1	56,9
4,5	53,3	60,5
5	56,3	64,1
Bar	L/min	

Z030203 000



MISCELATORE TERMOSTATICO 3 USCITE - 3 outlets thermostatic mixer - 3 Ausgänge Thermostat Brausebatterie
Mitigeur thermostatique 3 voies - Mezclador termostático 3 vias - Смеситель термостатический 3 выход

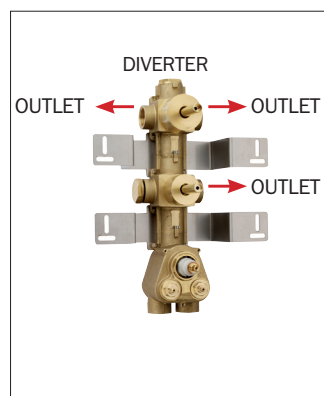

TEMPERATURA ACQUA MISCELATA - Mixed water temperature - Temperatur des gemischten Wassers - Température eau mitigée - Temperatura agua mezclada - Температура смешанной воды	38°C
TEMPERATURA ACQUA FREDDA - Cold water temperature - Kaltwassertemperatur - Température eau froide - Temperatura agua fría - Температура холодной воды	<20°C
TEMPERATURA ACQUA CALDA - Hot water temperature - Warmwassertemperatur - Température eau chaude - Temperatura agua caliente - Температура горячей воды	55-65°C
COLLEGAMENTO Connection Anschluss Raccordement Conexión Соединение	DIRETTO 3/4" direct 3/4" direkt 3/4" direct 3/4" directo 3/4" Прямое 3/4"

	1 Deviatore	1 Rubinetto	1 Deviatore + 1 Rubinetto
0	0,0	0,0	0,0
0,5	15,8	17,4	19,0
1	21,7	25,0	27,0
1,5	26,4	30,9	33,3
2	30,5	35,4	38,1
2,5	34,0	39,5	42,3
3	37,5	43,3	46,2
3,5	40,8	46,6	49,7
4	43,7	50,1	53,5
4,5	46,6	53,3	56,9
5	49,4	56,3	60,1
Bar	L/min		

Z030202 000



MISCELATORE TERMOSTATICO 3 USCITE - 3 outlets thermostatic mixer - 3 Ausgänge Thermostat Brausebatterie
Mitigeur thermostatique 3 voies - Mezclador termostático 3 vias - Смеситель термостатический 3 выход

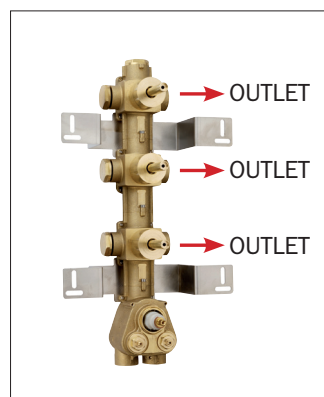

TEMPERATURA ACQUA MISCELATA - Mixed water temperature - Temperatur des gemischten Wassers - Température eau mitigée - Temperatura agua mezclada - Температура смешанной воды	38°C
TEMPERATURA ACQUA FREDDA - Cold water temperature - Kaltwassertemperatur - Température eau froide - Temperatura agua fría - Температура холодной воды	<20°C
TEMPERATURA ACQUA CALDA - Hot water temperature - Warmwassertemperatur - Température eau chaude - Temperatura agua caliente - Температура горячей воды	55-65°C
COLLEGAMENTO Connection Anschluss Raccordement Conexión Соединение	DIRETTO 3/4" direct 3/4" direkt 3/4" direct 3/4" directo 3/4" Прямое 3/4"

	1 USCITA	2 USCITE	3 USCITE
0	0,0	0,0	0,0
0,5	17,4	19,2	19,6
1	25,0	27,9	28,4
1,5	30,9	34,3	34,8
2	35,4	39,9	40,5
2,5	39,5	44,9	45,4
3	43,3	49,1	49,7
3,5	46,6	53,4	54,1
4	50,1	56,9	57,7
4,5	53,3	60,5	61,7
5	56,3	64,1	65,3
Bar	L/min		

Z030270 000



MISCELATORE TERMOSTATICO 4 USCITE - 4 outlets thermostatic mixer - 4 Ausgänge Thermostat Brausebatterie
Mitigeur thermostatique 4 voies - Mezclador termostático 4 vias - Смеситель термостатический 4 выход

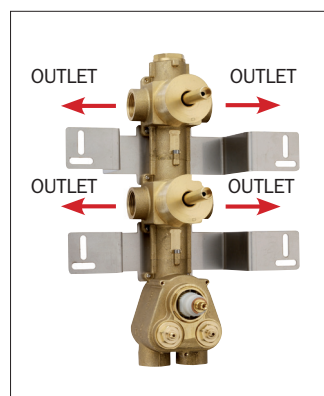

TEMPERATURA ACQUA MISCELATA - Mixed water temperature - Temperatur des gemischten Wassers - Température eau mitigée - Temperatura agua mezclada - Температура смешанной воды	38°C
TEMPERATURA ACQUA FREDDA - Cold water temperature - Kaltwassertemperatur - Température eau froide - Temperatura agua fría - Температура холодной воды	<20°C
TEMPERATURA ACQUA CALDA - Hot water temperature - Warmwassertemperatur - Température eau chaude - Temperatura agua caliente - Температура горячей воды	55-65°C
COLLEGAMENTO Connection Anschluss Raccordement Conexión Соединение	DIRETTO 3/4" direct 3/4" direkt 3/4" direct 3/4" directo 3/4" Прямое 3/4"

	1 USCITA DEVIATORE	2 USCITE DEVIATORE
0	0,0	0,0
0,5	15,8	18,3
1	21,7	25,6
1,5	26,4	31,3
2	30,5	35,7
2,5	34,0	39,3
3	37,5	42,9
3,5	40,8	46,3
4	43,7	49,7
4,5	46,6	52,9
5	49,4	55,9
Bar	L/min	

Z030271 000

MISCELATORE TERMOSTATICO 4 USCITE - 4 outlets thermostatic mixer - 4 Ausgänge Thermostat Brausebatterie
 Mitigeur thermostatique 4 voies - Mezclador termostático 4 vias - Смеситель термостатический 4 выход

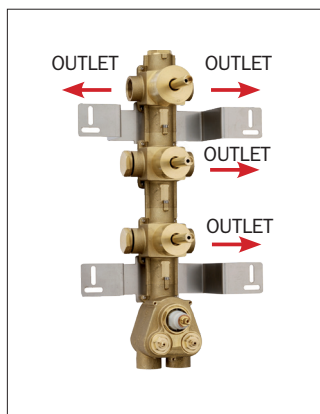

TEMPERATURA ACQUA MISCELATA - Mixed water temperature - Temperatur des gemischten Wassers - Température eau mitigée - Temperatura agua mezclada - Температура смешанной воды	38°C
TEMPERATURA ACQUA FREDDA - Cold water temperature - Kaltwassertemperatur - Température eau froide - Temperatura agua fría - Температура холодной воды	<20°C
TEMPERATURA ACQUA CALDA - Hot water temperature - Warmwassertemperatur - Température eau chaude - Temperatura agua caliente - Температура горячей воды	55-65°C
COLLEGAMENTO Connection Anschluss Raccordement Conexión Соединение	DIRETTO 3/4" direct 3/4" direkt 3/4" direct 3/4" directo 3/4" Прямое 3/4"

	1 USCITA DEV	1 USCITA RUB	1 USCITA RUB + 1 USCITA DEV	2 USCITE RUB	3 USCITE
0	0,0	0,0	0,0	0,0	0,0
0,5	15,8	17,4	19,0	19,2	19,3
1	21,7	25,0	27,0	27,9	28,1
1,5	26,4	30,9	33,3	34,3	34,5
2	30,5	35,4	38,1	39,9	40,1
2,5	34,0	39,5	42,3	44,9	45,1
3	37,5	43,3	46,2	49,1	49,4
3,5	40,8	46,6	49,7	53,4	53,6
4	43,7	50,1	53,5	56,9	57,2
4,5	46,6	53,3	56,9	60,5	60,9
5	49,4	56,3	60,1	64,1	64,4
Bar	L/min				

Z030210 000

MISCELATORE TERMOSTATICO 5 USCITE - 5 outlets thermostatic mixer - 5 Ausgänge Thermostat Brausebatterie
 Mitigeur thermostatique 5 voies - Mezclador termostático 5 vias - Смеситель термостатический 5 выход

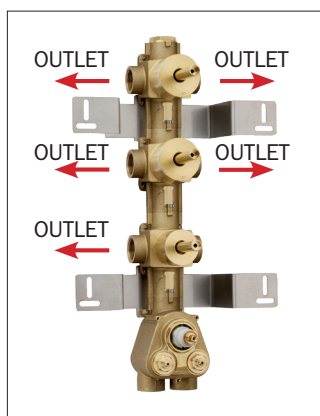

TEMPERATURA ACQUA MISCELATA - Mixed water temperature - Temperatur des gemischten Wassers - Température eau mitigée - Temperatura agua mezclada - Температура смешанной воды	38°C
TEMPERATURA ACQUA FREDDA - Cold water temperature - Kaltwassertemperatur - Température eau froide - Temperatura agua fría - Температура холодной воды	<20°C
TEMPERATURA ACQUA CALDA - Hot water temperature - Warmwassertemperatur - Température eau chaude - Temperatura agua caliente - Температура горячей воды	55-65°C
COLLEGAMENTO Connection Anschluss Raccordement Conexión Соединение	DIRETTO 3/4" direct 3/4" direkt 3/4" direct 3/4" directo 3/4" Прямое 3/4"

	1 USCITA DEV	1 USCITA RUB	1 USCITA RUB + 1 USCITA DEV	2 USCITE DEV	3 USCITE
0	0,0	0,0	0,0	0,0	0,0
0,5	15,8	17,4	19,0	18,3	19,1
1	21,7	25,0	27,0	25,6	27,3
1,5	26,4	30,9	33,3	31,3	33,7
2	30,5	35,4	38,1	35,7	38,7
2,5	34,0	39,5	42,3	39,3	43,2
3	37,5	43,3	46,2	42,9	47,1
3,5	40,8	46,6	49,7	46,3	50,8
4	43,7	50,1	53,5	49,7	54,5
4,5	46,6	53,3	56,9	52,9	58,0
5	49,4	56,3	60,1	55,9	61,2
Bar	L/min				

Z030275 000

MISCELATORE TERMOSTATICO 5 USCITE - 5 outlets thermostatic mixer - 5 Ausgänge Thermostat Brausebatterie
 Mitigeur thermostatique 5 voies - Mezclador termostático 5 vias - Смеситель термостатический 5 выход

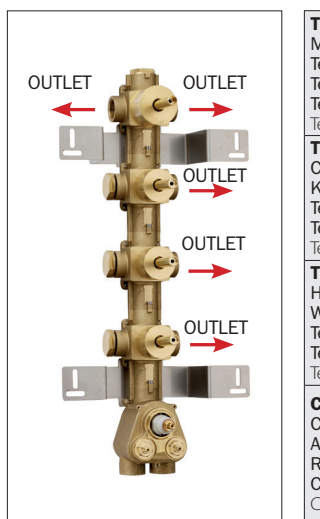

TEMPERATURA ACQUA MISCELATA - Mixed water temperature - Temperatur des gemischten Wassers - Température eau mitigée - Temperatura agua mezclada - Температура смешанной воды	38°C
TEMPERATURA ACQUA FREDDA - Cold water temperature - Kaltwassertemperatur - Température eau froide - Temperatura agua fría - Температура холодной воды	<20°C
TEMPERATURA ACQUA CALDA - Hot water temperature - Warmwassertemperatur - Température eau chaude - Temperatura agua caliente - Температура горячей воды	55-65°C
COLLEGAMENTO Connection Anschluss Raccordement Conexión Соединение	DIRETTO 3/4" direct 3/4" direkt 3/4" direct 3/4" directo 3/4" Прямое 3/4"

	1 USCITA DEV	1 USCITA RUB	1 USCITA RUB + 1 USCITA DEV	2 USCITE RUB	1 USCITA RUB + 1 USCITA DEV	3 USCITE RUB	3 USCITE RUB + 1 USCITA DEV
0	0,0	0,0	0,0	0,0	0,0	0,0	0,0
0,5	15,8	17,4	19,0	19,2	19,3	19,6	19,6
1	21,7	25,0	27,0	27,9	28,1	28,4	28,4
1,5	26,4	30,9	33,3	34,3	34,5	34,8	34,8
2	30,5	35,4	38,1	39,9	40,1	40,5	40,5
2,5	34,0	39,5	42,3	44,9	45,1	45,4	45,5
3	37,5	43,3	46,2	49,1	49,4	49,7	49,7
3,5	40,8	46,6	49,7	53,4	53,6	54,1	54,1
4	43,7	50,1	53,5	56,9	57,2	57,7	57,7
4,5	46,6	53,3	56,9	60,5	60,9	61,7	61,7
5	49,4	56,3	60,1	64,1	64,4	65,3	65,3
Bar	L/min						

Z030273 000



MISCELATORE TERMOSTATICO 6 USCITE - 6 outlets thermostatic mixer - 6 Ausgänge Thermostat Brausebatterie
 Mitigeur thermostatique 6 voies - Mezclador termostático 6 vías - Смеситель термостатический 6 выход

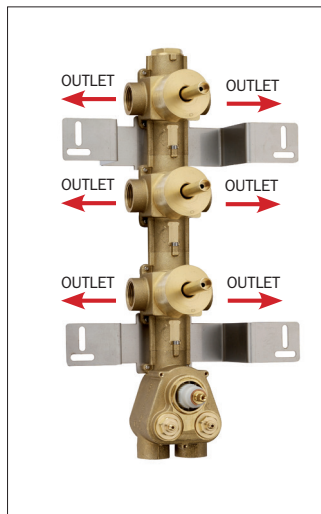

TEMPERATURA ACQUA MISCELATA Mixed water temperature Temperatur des gemischten Wassers Température eau mitigée Temperatura agua mezclada Температура смешанной воды	38°C
TEMPERATURA ACQUA FREDDA Cold water temperature Kaltwassertemperatur Température eau froide Temperatura agua fría Температура холодной воды	<20°C
TEMPERATURA ACQUA CALDA Hot water temperature Warmwassertemperatur Température eau chaude Temperatura agua caliente Температура горячей воды	55-65°C
COLLEGAMENTO Connection Anschluss Raccordement Conexión Соединение	DIRETTO 3/4" direct 3/4" direkt 3/4" direct 3/4" directo 3/4" Прямое 3/4"

	1 USCITA DEVIATORE	2 USCITE DEVIATORE	3 USCITE DEVIATORE
0	0,0	0,0	0,0
0,5	15,8	18,3	18,5
1	21,7	25,6	26,2
1,5	26,4	31,3	32,1
2	30,5	35,7	36,9
2,5	34,0	39,3	40,9
3	37,5	42,9	44,6
3,5	40,8	46,3	48,1
4	43,7	49,7	51,5
4,5	46,6	52,9	54,8
5	49,4	55,9	57,8
Bar	L/min		

HP = High Pressure / LP = Low Pressure



Funzionalità di installazione - Installation features - Optimale Einstellung

Caractéristiques d'installation - Características de instalación - Возможности установки

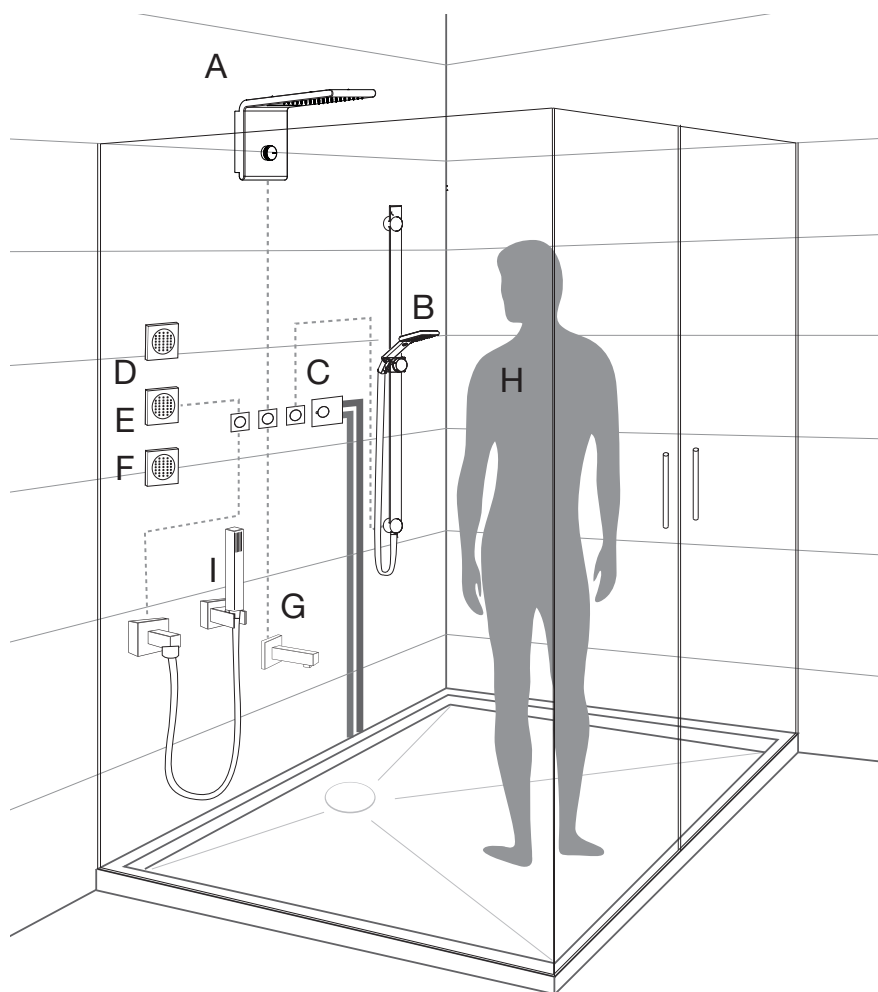

L'altezza ottimale di collocazione dei singoli prodotti si determina in base all'altezza della persona.

Each individual product can be installed and adjusted to suit person's height.

Die optimale Einstellungshöhe der einzelnen Produkten hängt von der Höhe der Benutzer ab.

La hauteur optimale pour placer chacun des produits varie selon la taille de la personne.

La altura ideal de colocación de cada producto se realiza en base a la altura de la persona.

Оптимальная высота расположения отдельных предметов базируется на параметрах человеческого роста.

H		Altezza uomo / Man height Körperhöhe / Hauteur d'homme / Altura de la persona Высота человека	cm	160	170	180	190	200
A		Soffione / Shower head / Kopfbrause Pomme de douche / Rociador / Душ	cm	210	210	220	230	240
B		Set saliscendi / Slide rail set Brausestange / Barre de douche Barra ducha / Комплект со штангой	cm	160	170	180	190	200
C		Miscelatore / Mixer / Brausebatterie / Mitigeur Mezclador / Смеситель	cm	115	120	125	130	135
D		Soffioni laterali superiori / Upper body sprays Obere Seitendüsen / Bodyjets latéraux supérieurs Duchas laterales superiores / Верхние боковые форсунки	cm	130	140	150	160	170
E		Soffioni laterali medi / Middle body sprays Mittlere Seitendüsen / Bodyjets latéraux moyens Duchas laterales medias / Серединные боковые форсунки	cm	95	105	115	125	135
F		Soffioni laterali inferiori / Lower body sprays Untere Seitendüsen / Bodyjets latéraux inférieurs Duchas laterales inferiores / Нижние боковые форсунки	cm	60	70	80	90	95
G		Bocca di erogazione / Foot spout / Fußdusche Lave-pieds / Caño mural / Кран для ног	cm	25	25	30	30	35
I		Supporti Doccia / Shower Brackets / Brausehalter Supports de douche / Soportes mango ducha / Держатели для душей	cm	115	120	125	130	135

TECHNICAL FEATURES

CARATTERISTICHE TECNICHE DEI TERMOSTATICI ALTA PORTATA

Tutti i termostatici ad alta portata hanno attacchi da 3/4" e possono essere installati in verticale (con entrata dell'acqua calda e fredda rivolte verso il basso) o in orizzontale (con entrate dell'acqua calda e fredda rivolte verso il lato destro o sinistro). Una delle caratteristiche principali del sistema termostatico alta portata di Bossini è che funziona in modo ottimale anche in condizioni di bassa pressione. Esistono due tipologie di termostatici: bassa pressione LP (Low Pressure) con rubinetti singoli, oppure alta pressione HP (High Pressure) con l'utilizzo del rubinetto/deviatore 2 vie.

TECHNICAL FEATURES OF HIGH FLOW THERMOSTATIC MIXERS

All the high flow thermostatic mixers have 3/4" connections and can be installed vertically (with the incoming hot and cold water directed downwards) or horizontally (with the incoming hot and cold water on the left or the right). One of the main features of the Bossini high flow thermostatic system is that it works well even in low pressure conditions. There are two types of thermostatic mixer: Low Pressure LP with single taps, or High Pressure HP by using a 2 way tap/diverter.

TECHNISCHE EIGENSCHAFTEN DER HOCHDURCHFLUSS THERMOSTAT-BATTERIE

Alle Hochdurchfluss Thermostat-Batterie von Bossini haben 3/4" Anschlüsse und können sowohl senkrecht (mit Warm- und Kaltwassereingang nach unten) als auch waagrecht (mit Warm- und Kaltwassereingang nach rechts oder links) eingebaut werden. Ein der wichtigsten Vorteile der Hochdurchfluss Thermostat-Brausebatterie liegt darin, dass sie auch bei Niederdruck optimal arbeiten können. Zwei verschiedenen Typen sind erhältlich: LP (Low Pressure) Niederdruck Batterie mit Einzelstoppventilen oder HP (High Pressure) Hochdruck Batterie mit 2-Wege Umstellventilen.

CARACTÉRISTIQUES TECHNIQUES DES MITIGEURS THERMOSTATIQUES

Tous les mitigeurs thermostatiques haut débit sont dotés de raccords 3/4" et peuvent se monter en position verticale (l'entrée de l'eau chaude et froide dirigée vers le bas) ou en position horizontale (l'entrée de l'eau chaude et froide dirigée à droite ou à gauche). L'une des principales caractéristiques du système haut débit Bossini repose sur sa capacité de fonctionnement optimal aussi en conditions de basse pression. Il existe deux types de mitigeurs thermostatiques: basse pression LP (Low Pressure) dotés de robinets individuels ou haute pression HP (High Pressure) avec l'utilisation du robinet/inverseur à 2 voies.

CARACTERÍSTICAS TÉCNICAS DE LOS MEZCLADORES THERMOSTÁTICOS ALTA CAPACIDAD

Todas los mezcladores termostáticos alta capacidad tienen conexiones de 3/4" y pueden ser instalados en vertical (con entrada del agua caliente y fría hacia abajo) o en horizontal (con entradas del agua caliente y fría hacia el lado derecho o izquierdo). Una de las características principales del sistema termostático alta capacidad de Bossini es que funciona óptima mente también en condiciones de baja presión. Existen dos tipos de mezcladores termostáticos: baja presión LP (Low Pressure) con grifos simples o bien alta presión HP (High Pressure) con grifos/desviadores de 2 vías.

ТЕХНИЧЕСКИЕ ХАРАКТЕРИСТИКИ СМЕСИТЕЛЕЙ ВЫСОКОЙ ПРОПУСКНОЙ СПОСОБНОСТИ

Все термостаты высокой пропускной способности имеют соединение на 3/4" и могут быть установлены вертикально (входы горячей и холодной воды повернуты к низу) или горизонтально (входы горячей и холодной воды повернуты в правую или левую сторону). Одна из основных особенностей системы термостатов высокой пропускной способности от Bossini – оптимальная функциональность, даже при низком давлении. Есть два вида термостатов: **низкого давления LP (Low Pressure)** с отдельными запорными кранами или **высокого давления HP (High Pressure)** с использованием крана/девиатора на 2 направления.

PRESSIONE DINAMICA - Dynamic Pressure - Staudruck - Pression Dynamique - Presion dinámica - динамическое давление	BASSA PRESSIONE Low Pressure - Basse pression - Niederdruck - Baja presión - низкое давление	ALTA PRESSIONE High Pressure - Haute Pression - Hochdruck - Alta Presión - высокое давление
MINIMA - Minimum Pressure - Mindestdruck - Pression minimale Presión mínima - минимальный	0,1 bar	0,5 bar
MASSIMA - Maximum Pressure - Höchstdruck - Pression maximale Presión máxima - максимальный	2 bar	5 bar
CONSIGLIATA - Recommended Pressure - Empfohlener Druck Pression recommandée - Presión recomendada - рекомендованный	0,2 ÷ 1 bar	1 ÷ 3 bar

ATTENZIONE!

- In caso di pressione d'esercizio superiore ai 5 bar si consiglia l'utilizzo di riduttori di pressione
- If the operating pressure exceeds 5 bar, the use of pressure reducers is recommended
- Bei einem Betriebsdruck über 5 bar wird empfohlen, Druckminderer zu verwenden
- En cas de pression d'exercice supérieure a 5 bar, on conseille d'utiliser des reducteurs de pression
- En caso de que la presión de trabajo supere los 5 bares, se recomienda utilizar un reductor de presión
- В СЛУЧАЯХ, КОГДА ДАВЛЕНИЕ ПОДАЧИ ПРЕВЫШАЕТ 5 БАР, РЕКОМЕНДУЕМ ИСПОЛЬЗОВАТЬ ОГРАНИЧИТЕЛИ ДАВЛЕНИЯ

BLOCCO TEMPERATURA DI SICUREZZA Temperature safety block - Blocage température de sécurité - Temperatur Sicherheitsblockierung - Bloque Temperatura de seguridad - Предохранительный блок температуры	38°C - 42°C - 46°C
TEMPERATURA ACQUA FREDDA Cold water temperature - Température eau froide - Kaltwasser Temperatur - Temperatura agua fría - Температура холодной воды	≤20°C
TEMPERATURA ACQUA CALDA Hot water temperature - Température eau chaude - Warmwasser Temperatur - Temperatura agua caliente - Температура горячей воды	55°C ÷ 65°C

Oki



Cube



Liberty



Inox



Alta Portata

High flow thermostatic



Parti di ricambio

Spare parts

OKI

CODICE/CODE

01	Aeratore a scomparsa e chiave Hidden aerator and key	Z000303 000	
02	Aeratore per bidet Aerator for bidet mixer	Z000356 021 Z000356 030 Z000356 073 Z000356 094	
03	Aeratore per gruppo vasca Aerator for bathtub mixer	Z000102 021 Z000102 030 Z000102 073 Z000102 094	
04	Aeratore per lavabo Aerator for wash basin mixer	Z000355 030	
05	Kit cartuccia, per LAVABO/BIDET Cartridge set for lavabo/bidet mixer	Z000357 021 Z000357 030 Z000357 073 Z000357 094	
06	Kit cartuccia MONOCOMANDO Cartridge set for single lever mixer	Z00212 021 Z00212 030 Z00212 073 Z00212 094	
07	Deviatore vasca con pomolo Diverter for bathtub mixer with knob	Z00213 021 Z00213 030 Z00213 073 Z00213 094	
08	Cartuccia miscelatore per ESTERNO DOCCIA MONOCOMANDO Mixing cartridge for exposed single lever mixer	Z00205 000	
09	Cartuccia miscelatore x ESTERNO DOCCIA TERMOSTATICO Mixing cartridge for exposed thermostatic mixer	Z00206 000	
10	Cartuccia deviatore 2-3-4-5 vie x MONOCOMANDO 2/3/4/5-ways diverter cartridge for single lever mixer	Z00202 000	
11	Cartuccia deviatore 2-3-4-5 vie x TERMOSTATICO 2/3/4/5-ways diverter cartridge for thermostatic mixer	Z00203 000	
12	Kit Cartuccia miscelatore x MONOCOMANDO Mixing cartridge set for single lever mixer	Z00201 021 Z00201 030 Z00201 073 Z00201 094	

Z00008	Z00007	Z00006	Z00005	Z00002	Z00125	Z00004	Z00130	Z005301	Z005401	Z005303	Z005302	Z005101	Z005130	Z005131	
											•				
									•						
												•			
								•		•					
								•	•	•					
												•			
												•			
													•		
							•								
					•										
	•		•				•								

OKI

CODICE/CODE

13	Kit Cartuccia miscelatore per TERMOSTATICO Mixing cartridge set for thermostatic mixer	Z00204 000	
14	Deviatore c/pomolo per MONOCOMANDO inc. 2 Vie Diverter for concealed 2-ways single lever mixer with knob	Z10112 021 Z10112 030 Z10112 073 Z10112 094	
15	Piastra 120 x 120 Plate 120 x 120	Z10120 021 Z10120 030 Z10120 073 Z10120 094	
16	Piastra 170x120 Plate 170 x 120	Z10121 021 Z10121 030 Z10121 073 Z10121 094	
17	Piastra 210x120 Plate 210 x 120	Z10122 021 Z10122 030 Z10122 073 Z10122 094	
18	Manopola tonda MONOCOMANDO e dev. TERMOSTATICO Round handle for single lever mixer and thermostatic diverter	Z10105 021 Z10105 030 Z10105 073 Z10105 094	
19	Manopola tonda dev. MONOCOMANDO Round handle for single lever mixer diverter	Z10106 021 Z10106 030 Z10106 073 Z10106 094	
20	Manopola tonda TERMOSTATICO Round handle for thermostatic mixer	Z10107 021 Z10107 030 Z10107 073 Z10107 094	
21	EXPO Incasso MONOCOMANDO 1 via 1-way single lever mixer for exhibit	Z00086 021 Z00086 030 Z00086 073 Z00086 094	
22	EXPO Incasso MONOCOMANDO 2 vie a pulsante 2-ways concealed single lever mixer with knob for exhibit	Z00082 021 Z00082 030 Z00082 073 Z00082 094	
23	EXPO Incasso MONOCOMANDO 2-3-4-5 vie 2/3/4/5-ways concealed single lever mixer for exhibit	Z00081 021 Z00081 030 Z00081 073 Z00081 094	
24	EXPO Incasso TERMOSTATICO 2-3-4-5 vie 2/3/4/5-ways concealed thermostatic mixer for exhibit	Z00080 021 Z00080 030 Z00080 073 Z00080 094	

Z00008	Z00007	Z00006	Z00005	Z00002	Z00125	Z00004	Z00130	Z005301	Z005401	Z005303	Z005302	Z005101	Z005130	Z005131	
					•										
			•												
•															
		•													
				•		•									
•		•		•		•									
						•									
				•											
•															
		•													
						•									
				•											

OKI

CODICE/CODE









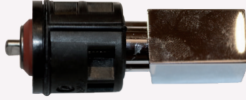

25	KIT PROLUNGA MONOCOMANDO 1 via - Max 25mm Set extension for single lever mixer 1-way - Max 25mm	Z00078 021 Z00078 030 Z00078 073 Z00078 094	
26	KIT PROLUNGHE MONOCOMANDO 2 vie a pulsante - Max 25mm Set extensions for single lever mixer 2-ways - Max 25mm	Z00072 021 Z00072 030 Z00072 073 Z00072 094	
27	KIT PROLUNGHE MONOCOMANDO 2-3-4-5 vie - Max 25mm Set extensions for single lever mixer 2/3/4/5-ways - Max 25mm	Z00077 021 Z00077 030 Z00077 073 Z00077 094	
28	KIT PROLUNGHE TERMOSTATICO 2-3-4-5 vie - Max 25mm Set extensions for thermostatic mixer 2/3/4/5-ways - Max 25mm	Z00076 021 Z00076 030 Z00076 073 Z00076 094	

		CODICE/CODE	Z005350	Z005351	Z005360	Z005361
29	Piastra intera 318 x 100 Complete plate 318 x 100	Z10132 030		•	•	
30	Manopola Tonda TERMOSTATICO completa Complete round handle for thermostatic mixer	Z10134 030		•	•	
31	Manopola Tonda rub/dev completa Complete round handle for mixer and diverter	Z10135 030		•	•	
32	Cartuccia TERMOSTATICA Thermostatic cartridge	Z000408 000		•	•	
33	Vitone per deviatore Headwork for diverter	Z000407 000		•	•	
34	Deviatore c/pomolo per MONOCOMANDO inc. 2 Vie Diverter with knob for 2-ways concealed single lever mixer	Z10112 021 Z10112 030 Z10112 073 Z10112 094				•
35	Manopola MONOCOMANDO Handle for single lever mixer	Z10125 030				•
36	Piastra intera 220 x 90 Complete plate 220 x 90	Z10139 030				•

Z00008																	
Z00007	•																
Z00006																	
Z00005		•															
Z00002																	
Z00125						•											
Z00004																	
Z00130							•										
Z005301																	
Z005401																	
Z005303																	
Z005302																	
Z005101																	
Z005130																	
Z005131																	

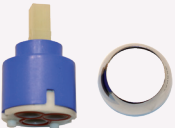
CUBE

CODICE/CODE

01	Aeratore per lavabo Aerator for wash basin mixer	Z000304 000	
02	Aeratore per bidet Aerator for bidet mixer	Z000402 021 Z000402 030 Z000402 073 Z000402 094	
03	Kit cartuccia MONOCOMANDO Set cartridge for single lever mixer	Z000030 021 Z000030 030 Z000030 073 Z000030 094	
04	Deviatore vasca con pomolo Diverter for bathtub with knob	Z000105 021 Z000105 030 Z000105 073 Z000105 094	
05	Cartuccia TERMOSTATICA ESTERNO DOCCIA Thermostatic cartridge for exposed shower mixer	Z000106 000	
09	Cartuccia deviatore 2-3-4-5 vie per MONOCOMANDO 2/3/4/5-ways diverter cartridge for single lever mixer	Z00202 000	
10	Cartuccia deviatore 2-3-4-5 vie per TERMOSTATICO 2/3/4/5-ways diverter cartridge for thermostatic mixer	Z00203 000	
11	Cartuccia miscelatore per MONOCOMANDO Mixing cartridge for single lever mixer	Z00201 021 Z00201 030 Z00201 073 Z00201 094	
12	Cartuccia miscelatore per TERMOSTATICO Mixing cartridge for thermostatic mixer	Z00204 000	
13	Deviatore c/pomolo quadro per MONOCOMANDO inc. 2 Vie Diverter with square knob for 2-ways single lever concealed mixer	Z10109 021 Z10109 030 Z10109 073 Z10109 094	
14	Piastra 120 x 120 Plate 120 x 120	Z10120 021 Z10120 030 Z10120 073 Z10120 094	
15	Piastra 170 x 120 Plate 170 x 120	Z10121 021 Z10121 030 Z10121 073 Z10121 094	

Z00064	Z00007	Z00063	Z00005	Z00061	Z00125	Z00062	Z00130	Z004301	Z004401	Z004303	Z004302	Z004101	Z004102	Z004103	
								•		•	•	•			
									•						
								•	•	•	•	•	•		
												•			
													•		
							•								
		•		•				•							
			•												
•															
		•													

CUBE

CODICE/CODE

16	Piastra 210x120 Plate 210 x 120	Z10122 021 Z10122 030 Z10122 073 Z10122 094	
17	Manopola quadra MONOCOMANDO e dev. TERMOSTATICO Square handle for single lever mixer and thermostatic diverter	Z10108 021 Z10108 030 Z10108 073 Z10108 094	
18	Manopola quadra dev. MONOCOMANDO Square handle for single lever mixer diverter	Z10110 021 Z10110 030 Z10110 073 Z10110 094	
19	Manopola quadra TERMOSTATICO Square handle for thermostatic mixer	Z10111 021 Z10111 030 Z10111 073 Z10111 094	
20	EXPO Incasso MONOCOMANDO 1 via 1-way single lever mixer for exhibit	Z00087 021 Z00087 030 Z00087 073 Z00087 094	
21	EXPO Incasso MONOCOMANDO 2 vie a pulsante 2-ways concealed single lever mixer with knob for exhibit	Z00085 021 Z00085 030 Z00085 073 Z00085 094	
22	EXPO Incasso MONOCOMANDO 2-3-4-5 vie 2/3/4/5-ways concealed single lever mixer for exhibit	Z00084 021 Z00084 030 Z00084 073 Z00084 094	
23	EXPO Incasso TERMOSTATICO 2-3-4-5 vie 2/3/4/5-ways concealed thermostatic mixer for exhibit	Z00083 021 Z00083 030 Z00083 073 Z00083 094	
24	KIT PROLUNGA MONOCOMANDO 1 via - Max 25mm Set extension for single lever mixer 1-way - Max 25mm	Z00078 021 Z00078 030 Z00078 073 Z00078 094	
25	KIT PROLUNGHE MONOCOMANDO 2 vie a pulsante - Max 25mm Set extensions for single lever mixer 2-ways - Max 25mm	Z00072 021 Z00072 030 Z00072 073 Z00072 094	
26	KIT PROLUNGHE MONOCOMANDO 2-3-4-5 vie - Max 25mm Set extensions for single lever mixer 2/3/4/5-ways - Max 25mm	Z00077 021 Z00077 030 Z00077 073 Z00077 094	
27	KIT PROLUNGHE TERMOSTATICO 2-3-4-5 vie - Max 25mm Set extensions for thermostatic mixer 2/3/4/5-ways - Max 25mm	Z00076 021 Z00076 030 Z00076 073 Z00076 094	

Z00064	Z00007	Z00063	Z00005	Z00061	Z00125	Z00062	Z00130	Z004301	Z004401	Z004303	Z004302	Z004101	Z004102	Z004103	
				•		•									
•		•		•		•									
						•									
				•											
•															
		•													
						•									
				•											
	•														
			•												
							•								
					•										

LIBERTY

CODICE/CODE

01	Aeratore a scomparsa e chiave Hidden aerator and key	Z000303 000	
02	Aeratore per lavabo/bidet Aerator for wash basin and bidet mixer	Z000305 021 Z000305 022 Z000305 030 Z000305 094	
03	Vitone ceramica 90° DX Ceramic headwork 90° right	Z000031 000	
04	Vitone ceramica 90° SX Ceramic headwork 90° left	Z000032 000	
05	Vitone prolungato DX Extended headwork right	Z000033 000	
06	Vitone prolungato SX Extended headwork left	Z000034 000	
07	Deviatore vasca con pomolo Bathtub diverter with knob	Z000104 021 Z000104 022 Z000104 030 Z000104 094	
08	Cartuccia deviatore 2-3-4-5 vie x MONOCOMANDO 2/3/4/5-ways diverter cartridge for single lever mixer	Z00202 000	
09	Cartuccia deviatore 2-3-4-5 vie x TERMOSTATICO 2/3/4/5-ways diverter cartridge for thermostatic mixer	Z00203 000	
10	Cartuccia miscelatore x MONOCOMANDO Mixing cartridge for single lever mixer	Z00201 021 Z00201 022 Z00201 030 Z00201 094	
11	Cartuccia miscelatore x TERMOSTATICO Mixing cartridge for thermostatic mixer	Z00204 000	
12	Deviatore c/pomolo per MONOCOMANDO inc. 2 Vie Diverter with knob for 2-ways single lever mixer	Z10112 021 Z10112 022 Z10112 030 Z10112 094	

Z00067	Z00007	Z00066	Z00005	Z00068	Z00125	Z00065	Z00130	Z001403	Z001301	Z001401	Z001302	Z001402	Z001303	Z001103	Z001403
													•		
									•	•	•	•			
									•	•	•	•		•	•
									•	•	•	•		•	•
													•		
													•		
														•	
								•							
	•		•					•							
					•										
			•												

LIBERTY

CODICE/CODE

13	Piastra 120 x 120 Plate 120 x 120	Z10120 021 Z10120 022 Z10120 030 Z10120 094	
14	Piastra 170 x 120 Plate 170 x 120	Z10121 021 Z10121 022 Z10121 030 Z10121 094	
15	Piastra 210 x 120 Plate 210 x 120	Z10122 021 Z10122 022 Z10122 030 Z10122 094	
16	Manopola LIBERTY MONOCOMANDO Liberty handle for single lever mixer	Z10101 021 Z10101 022 Z10101 030 Z10101 094	
17	Manopola LIBERTY dev. MONOCOMANDO Liberty handle for single lever mixer diverter	Z10102 021 Z10102 022 Z10102 030 Z10102 094	
18	Manopola LIBERTY TERMOSTATICO Liberty handle for thermostatic mixer	Z10103 021 Z10103 022 Z10103 030 Z10103 094	
19	Manopola LIBERTY dev. TERMOSTATICO Liberty handle for thermostatic mixer diverter	Z10104 021 Z10104 022 Z10104 030 Z10104 094	
20	EXPO Incasso MONOCOMANDO 1 via 1-way single lever mixer for exhibit	Z00091 021 Z00091 022 Z00091 030 Z00091 094	
21	EXPO Incasso MONOCOMANDO 2 vie a pulsante 2-ways concealed single lever mixer with knob for exhibit	Z00090 021 Z00090 022 Z00090 030 Z00090 094	
22	EXPO Incasso MONOCOMANDO 2-3-4-5 vie 2/3/4/5-ways concealed single lever mixer for exhibit	Z00089 021 Z00089 022 Z00089 030 Z00089 094	
23	EXPO Incasso TERMOSTATICO 2-3-4-5 vie 2/3/4/5-ways concealed thermostatic mixer for exhibit	Z00088 021 Z00088 022 Z00088 030 Z00088 094	
24	KIT PROLUNGA MONOCOMANDO 1 via - Max 25mm Set extension for single lever mixer 1-way - Max 25mm	Z00078 021 Z00078 022 Z00078 030 Z00078 094	

Z00067	Z00007	Z00066	Z00005	Z00068	Z00125	Z00065	Z00130	Z001403	Z001301	Z001401	Z001302	Z001402	Z001303	Z001103	Z001403	
•																
		•														
				•		•										
•		•				•										
						•										
				•												
•																
		•														
						•										
				•												
	•															

LIBERTY

CODICE/CODE

25	KIT PROLUNGHE MONOCOMANDO 2 vie a pulsante - Max 25mm Set extensions for single lever mixer 2-ways - Max 25mm	Z00072 021 Z00072 022 Z00072 030 Z00072 094	
26	KIT PROLUNGHE MONOCOMANDO 2-3-4-5 vie - Max 25mm Set extensions for single lever mixer 2/3/4/5-ways - Max 25mm	Z00077 021 Z00077 022 Z00077 030 Z00077 094	
27	KIT PROLUNGHE TERMOSTATICO 2-3-4-5 vie - Max 25mm Set extensions for thermostatic mixer 2/3/4/5-ways - Max 25mm	Z00076 021 Z00076 022 Z00076 030 Z00076 094	

LIBERTY

CODICE/CODE









28	Vitone ceramica 90° dx Ceramic headwork 90° right	Z000031 000	
29	Vitone ceramica 90° Sx Ceramic headwork 90° left	Z000032 000	
30	Deviatore vasca con pomolo Bathtub diverter with knob	Z000104 021 Z000104 022 Z000104 030 Z000104 094	

Z00064																
Z00007																
Z00063																
Z00005				•												
Z00061																
Z00062																
Z004301																
Z004401																
Z004303																
Z004302																
Z004101																
Z004102																
Z004103																
Z00125													•			
Z00130														•		

	Z001106		
	L00130		
	Z001101		
		•	•
		•	•
		•	•

INOX

CODICE/CODE

1	Cartuccia deviatore 2-3-4-5 vie x MONOCOMANDO 2/3/4/5-ways diverter cartridge for single lever mixer	Z00202 000	
2	Cartuccia deviatore 2-3-4-5 vie x TERMOSTATICO 2/3/4/5-ways diverter cartridge for thermostatic mixer	Z00203 000	
3	Kit Cartuccia miscelatore x MONOCOMANDO Mixing cartridge set for single lever mixer	Z00216 000	
4	Kit Cartuccia miscelatore per TERMOSTATICO Mixing cartridge set for thermostatic mixer	Z00204 000	
5	Piastra 120 x 120 Plate 120 x 120	Z10154 030 Z10154 075	
6	Piastra 210x120 Plate 210 x 120	Z10155 030 Z10155 075	
7	Manopola tonda MONOCOMANDO e dev. TERMOSTATICO Round handle for single lever mixer and thermostatic diverter	Z10151 030 Z10151 075	
8	Manopola tonda dev. MONOCOMANDO Round handle for single lever mixer diverter	Z10152 030 Z10152 075	
9	Manopola tonda TERMOSTATICO Round handle for thermostatic mixer	Z10153 030 Z10153 075	

INZ046	INZ002	INZ040	INZ002	INZ047	INZ042	INZ003
		•				
	•					
•						

			•			
				•		
					•	•
				•	•	•
					•	
						•

ALTA PORTATA

High flow thermostatic

		CODICE/CODE	
01	Cartuccia termostatica Thermostatic cartridge	Z000408 000	
02	Vitone per rubinetto Headwork for on-off valve	Z000406 000	
03	Vitone per deviatore Headwork for diverter	Z000407 000	

ALTA PORTATA

High flow thermostatic

		CODICE/CODE	
04	Piastra singola per manopola termo Single plate for thermostatic mixer handle	Z10130 030	
05	Piastra singola per manopola rub/dev Single plate for on-off valve/diverter handle	Z10131 030	
06	Piastra intera 318 x 100 Complete plate 318 x 100	Z10132 030	
07	Piastra intera 218 x 100 Complete plate 218 x 100	Z10133 030	
08	Manopola Tonda Termo completa Complete round handle for thermostatic mixer	Z10134 030	
09	Manopola Tonda rub/dev completa Complete round handle for on-off valve/diverter	Z10135 030	
10	Manopola Quadra Termo completa Complete square handle for thermostatic mixer	Z10136 030	
11	Manopola Quadra rub/dev completa Complete square handle for on-off valve/diverter	Z10137 030	
12	Manopola Rett. rub/dev completa Complete rectangular handle for on-off valve/diverter	Z10138 030	

Z030201	•	•	•	•	•	•	•	•	•	•									
Z030202	•	•	•	•	•	•	•	•	•	•									
Z030203	•	•	•	•	•	•	•	•	•	•									
Z030204	•	•	•	•	•	•	•	•	•	•									
Z030205	•	•	•	•	•	•	•	•	•	•									
Z030210	•	•	•	•	•	•	•	•	•	•									
Z030270	•	•	•	•	•	•	•	•	•	•									
Z030271	•	•	•	•	•	•	•	•	•	•									
Z030273	•	•	•	•	•	•	•	•	•	•									
Z030275	•	•	•	•	•	•	•	•	•	•									
Z031201	•	•	•	•	•	•	•	•	•	•									
Z032201	•	•	•	•	•	•	•	•	•	•									
Z033201	•	•	•	•	•	•	•	•	•	•									
Z031202	•	•	•	•	•	•	•	•	•	•									
Z032202	•	•	•	•	•	•	•	•	•	•									
Z033202	•	•	•	•	•	•	•	•	•	•									
Z031203	•	•	•	•	•	•	•	•	•	•									
Z032203	•	•	•	•	•	•	•	•	•	•									
Z033203	•	•	•	•	•	•	•	•	•	•									
Z031204	•	•	•	•	•	•	•	•	•	•									
Z032204	•	•	•	•	•	•	•	•	•	•									
Z033204	•	•	•	•	•	•	•	•	•	•									
Z031205	•	•	•	•	•	•	•	•	•	•									
Z032205	•	•	•	•	•	•	•	•	•	•									
Z033205	•	•	•	•	•	•	•	•	•	•									
Z031208	•	•	•	•	•	•	•	•	•	•									
Z032208	•	•	•	•	•	•	•	•	•	•									
Z033208	•	•	•	•	•	•	•	•	•	•									



BOSSINI SPA

Sede amministrativa / Head office:

25014 Castenedolo (Brescia) Italy

Via G. Matteotti, 170/A

Tel. +39 030 2134 211

Fax +39 030 2134 290

info@bossini.it

www.bossini.it

BOSSINI
SHOWER SYSTEMS

MADE IN ITALY

XLIS061000000-Mixer 2021

L'azienda si riserva in qualsiasi momento la facoltà di apportare tutte le modifiche necessarie al miglioramento estetico e qualitativo del prodotto.
The company reserves the right to make all the necessary changes for the purpose of constant improvement of quality, with no obligation to give prior notice.